

**Finsa**

# Solutions for mezzanines

SuperPan®Tech: Advanced technology  
for your projects

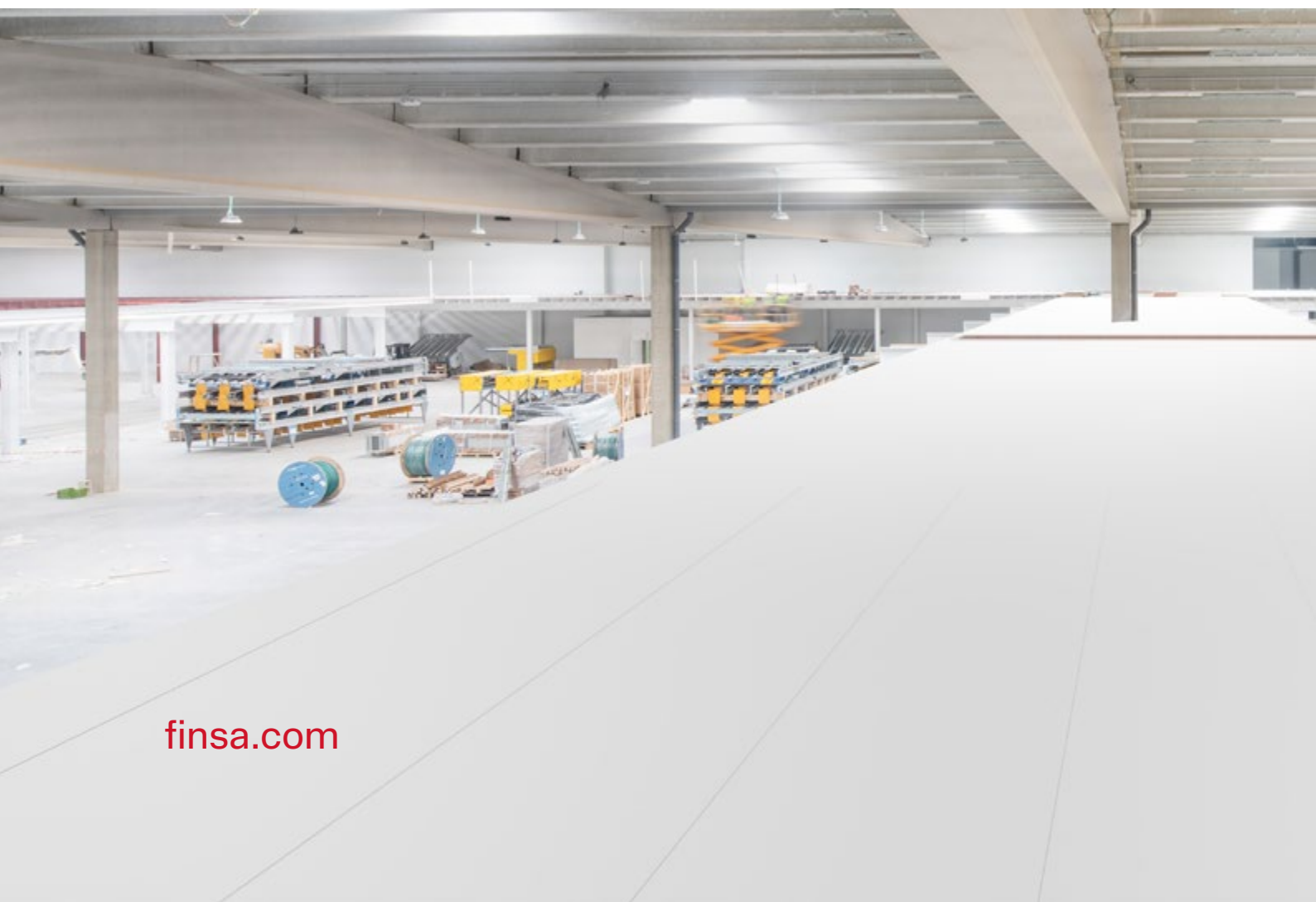

[finsa.com](https://finsa.com)



# Index

---

00/ Introduction

Page 5

---

01/ Sustainability

Page 6

---

02/ What is a mezzanine?

Page 8

---

Benefits of panels for use in mezzanines

Page 10

---

Finishes

Page 13

---

Abrasion resistance

Page 14

---

Behavior and reaction to fire

Page 16

---

03/ SuperPan® Tech

Page 18

---

---

04/ Availability

Page 20

---

05/ Technical information

Page 32

---

Offer characteristics

Page 32

---

Structural data

Page 34

---

General recommendations

Page 42

---

Installation recommendations

Page 44

---

06/ Other essays

Page 52

---



# Finsa

At Finsa we have been dedicated to industrial wood processing for almost a century, designing and manufacturing decorative and technical solutions for your spaces .

We work on a daily basis with the aim of responding to the needs of the construction, architecture, interior design and housing sectors, through the manufacture and transformation of wood-based products and the processing of solid wood. This is a transformation process whereby wood does not lose its qualities, but rather gains greater efficiency through an industrial process based on the circular economy system .

Finsa offers a wide range of technical wood panels and supports, providing its customers with different qualities, an extensive range of densities and thicknesses, and a wide variety of products for highly specialized needs or applications. This, and the possibility of combining them with our surfaces, allows us to offer the market an extensive portfolio of products adapted to all types of processes and applications, and for any type of project.

**You too, are invited to connect with Finsa**

# Wooden construction, sustainable construction

## Certificates



EPD®

### Environmental Product Declaration

It communicates the environmental impact of a material throughout its life cycle, from the raw material extraction process to the product manufacturing process.



### Cradle to Cradle

Multi-attribute certification, directly linked to the Sustainable Development Goals (SDGs), demonstrating that a product is safe and circular.



### The Material Health Certificate

This is a materials analysis based on the health assessment methodology of the Cradle to Cradle standard. This certification seeks to promote healthier and safer products.



### Forestry certifications

**PEFC** PEFC chain of custody certification provides a verified and independent guarantee that products with the PEFC label contain certified forest material from sustainably managed forests.

### FSC®

We have implemented an FSC® chain of custody certification system that allows us to supply certified wood products to customers, which are 100% recyclable and contribute greatly to the fight against climate change. This forest certification promotes certified wood, and to this end, we certify our farms and help our suppliers obtain their certification.



# 01/

Choosing our engineered wood panels means opting for a more environmentally friendly model and aligning with the European Union's sustainability goals. You contribute to the circularity of resources, support the sustainable management of forests, promote the socio-economic sustainability of rural areas, and actively participate in mitigating climate change.



## EUTR (EU Timber Regulation)

As a sign of transparency, we voluntarily certify compliance with EU regulation 995/2010 regarding the legal origin of wood.



We have external certification that verifies the self-declaration of recycled material content under the two reference standards:

### ISO 38200

This globally valid standard transmits information throughout the timber supply chain of the products derived from it.

### ISO 14021

Standard that establishes the requirements for environmental self-declarations made directly by manufacturers.

## Sustainable building certifications

### BREEAM, LEED, VERDE, WELL, and LBC

Our wood-based solutions help meet the requirements of sustainable building certifications.



# What is a mezzanine?



# 02/

A mezzanine or *mezzanine* is a structure built within the volume of another architectural space, an intermediate level or additional floor located between the ground floor and the first floor of a building, usually in large industrial spaces with great height, generating new surfaces for the facility's use and allowing the space to be used at different levels.

It is a very common solution for storage and logistics facilities to expand usable space.

Mezzanines are the ideal solution for increasing and optimizing the use of warehouses or other industrial spaces. They are a good

solution for gaining more usable space from the same existing volume. This is achieved by dividing the space vertically to create a new intermediate floor, allowing this extra surface to be used for different purposes.

They are normally composed of a self-supporting structure, independent of the main structure, and a lightweight floor ( SuperPan® Tech structural wood board).

## Multiple uses

- Increased storage capacity.
- Office installation.
- Generation of commercial spaces.
- Meeting areas.
- Facilities.
- Walkways.
- Exposure zones.

## Advantages

- Increase in usable area within the same existing volume.
- Space optimization.
- Easy installation . No major construction work required.
- Lightness.
- Dry assembly.
- Easily disassembled, to adapt to future space configurations.

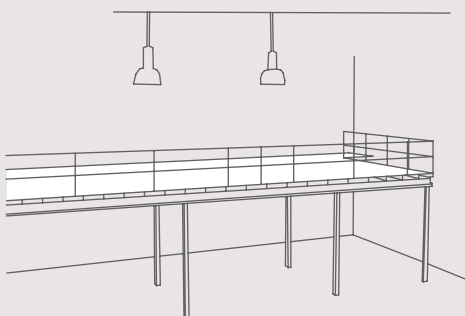

## Benefits of panels for use in mezzanines

The load-bearing capacity of a floor is determined by the strength and rigidity of the supporting structure, along with the performance of the floorboards and their connection profile. A load-bearing floor must meet both strength and deflection requirements. On the one hand, the floor must be strong enough to withstand all forces applied to it and, on the other hand, it must not deform excessively under its own weight and the variable bending load.

### Structural requirements and service class

The UNE-EN-312 standard classifies particleboards for interior applications in construction according to their structural qualities, such as:

- P4: Structural panels for use in dry environments.
- P5: Structural panels for use in humid environments.
- P6: High-performance structural panels for use in dry environments.
- P7: High-performance structural panels for use in humid environments.

and according to their service class:

#### Service class 1

It is characterized by a moisture content in the materials corresponding to a temperature of  $20 \pm 2^\circ\text{C}$  and a relative humidity of the air that only exceeds 65% for a few weeks a year.

#### Service class 2

It is characterized by a moisture content in the materials corresponding to a temperature of  $20 \pm 2^\circ\text{C}$  and a relative humidity of the air that only exceeds 85% for a few weeks a year.

### Tongue and groove (TG)

Having tongue and groove joints on the edges of the boards facilitates easy, simple assembly and a perfect fit between boards. Furthermore, by ensuring a rigid connection in the tongue and groove joint, we can make our floor act as a diaphragm and serve as horizontal stiffening for our mezzanine structure.

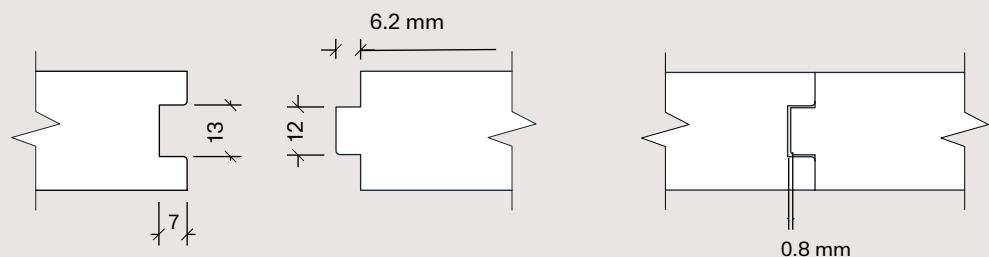

Tongue and groove detail of SuperPan® Tech for thicknesses between 25 and 40mm.

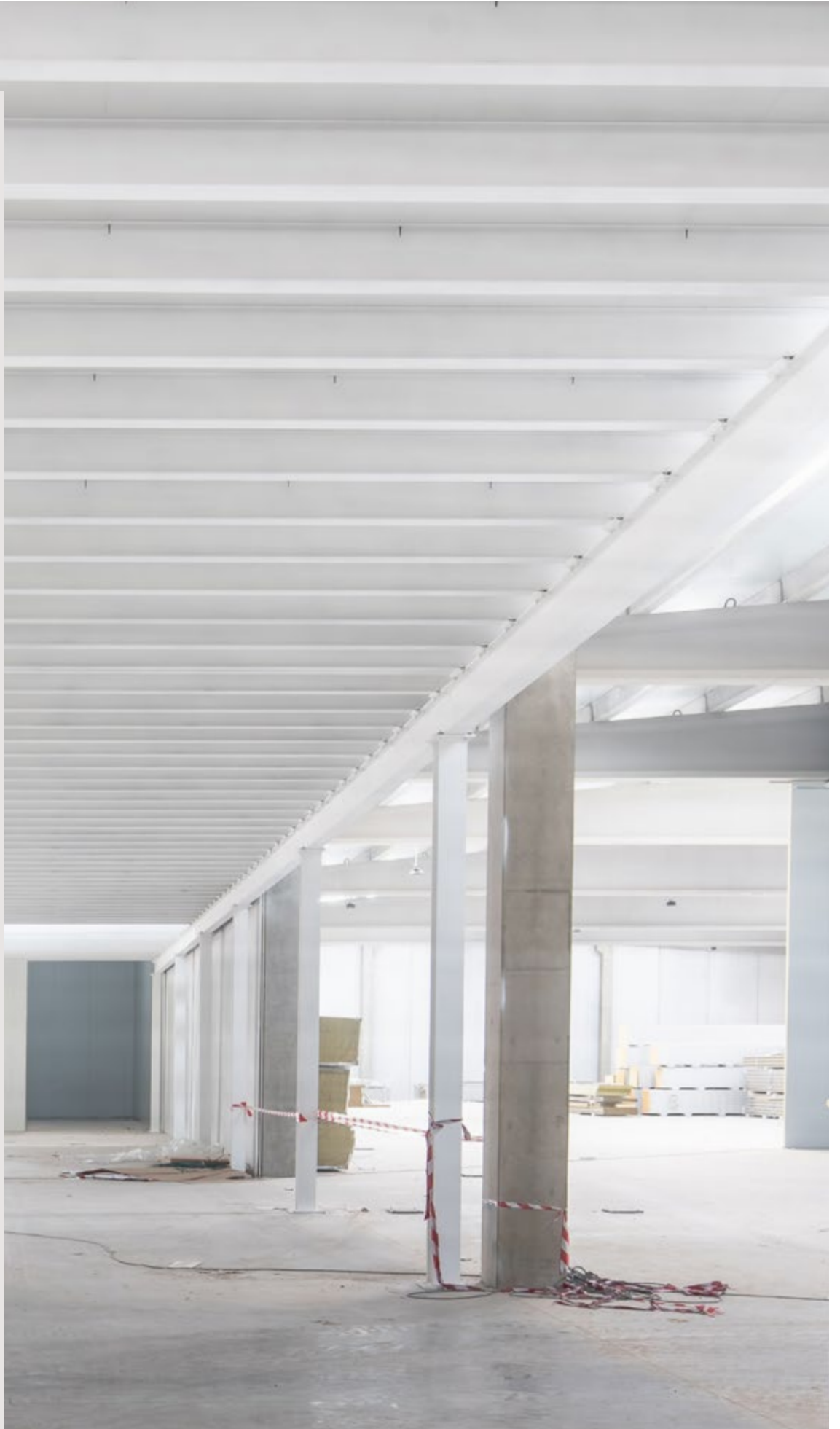



---

## Finishes

Structural panels are a versatile and efficient solution for floors subject to traffic. They can be coated with decorative paper and specific surface reliefs that offer direct and aesthetic finishes for the floor. In addition, there is the option of finishes with coarse sandpaper grain on the surface, designed to improve adhesion and reduce slipperiness, ideal for applications that require greater safety.

On the other hand, it is common to apply a high-quality white finish, especially if the panels are exposed. This finish improves light reflection, a particularly valuable characteristic in interior industrial spaces where brightness plays a crucial role.



Finishing detail  
non-slip (NS)



## Abrasion resistance

---

Depending on the intended use of the mezzanine floor, if we do not install an additional flooring on the slab, the abrasion resistance that the slab itself must withstand can be defined.

---

## Classification

**AC<sub>n</sub>**

To classify the abrasion and surface wear resistance of materials, the designation AC<sub>n</sub> is used (according to standard EN 13329), where *n* is a number (*n*= 3,4,5...) where the higher the number, the greater the wear resistance.

- AC<sub>3</sub>** — More than 2500 cycles
- AC<sub>4</sub>** — More than 4000 cycles
- AC<sub>5</sub>** — More than 6500 cycles
- AC<sub>6</sub>** — More than 8500 cycles



## Anti-slip

This concept is based on the critical angle of slip test for pavements in workplaces and work areas with a risk of slipping according to standard DIN 51130:2014 Suitable. 5.



Non-slip class	Angle	Example of surface	Grip / Adhesion
R9	From 6° to 10°	Smooth surfaces, dry areas.	Low grip
R10	> 10° to 19°	Surfaces with a slight texture.	Moderate grip
R11	> 19° to 27°	Rough surfaces, humid areas	Good grip.
R12	>27° to 35°	Very rough surfaces, food industry	High grip
R13	>35°	Very rough surfaces, industrial kitchens	Very high grip.

Fire behavior

Whenever the construction of a mezzanine is considered, the technical building regulations of the country where the work is to be carried out and their application must be reviewed. In this way, we verify whether the material to be applied needs to comply with any type of certification regarding its fire performance, whether for use in floors, ceilings, or both.

Fire reaction

The materials installed as final coatings, according to the industrial installation regulations, require a specific reaction to fire, differentiating according to their use as walls and ceilings or floors.

This required classification is based on the classification carried out by the European standard EN 13501-1 for all construction products, providing information on how they contribute to fire and how they affect safety during the evacuation process. The reaction to fire assesses the ability of a material to promote the development of fire, by measuring properties such as flame spread, heat emission, smoke production and falling flaming droplets.

The EN 13501-1 standard provides a classification of construction products according to Euroclasses:

**Classification according to reaction to fire (EN 13501-1)**

A1	They do not contribute to the spread of the fire.
A2	Practically no contribution to the spread of the fire.
B	Flammable with very little contribution to fire spread.
C	Flammable with little contribution to fire spread.
D	Flammable with medium contribution to fire spread.
E	Flammable with a very high contribution to fire spread.
F	Easily flammable. No performance requirements.

**Classification according to smoke production**

s1	No or little smoke production.
s2	Medium smoke production
s3	Heavy smoke production.

**Classification of droplet or particle production in flames**

d0	No droplets or particles are produced in flames.
d1	No droplets or particles are produced in flames with a persistence greater than a given period.
d2	There are no limitations.

**Walls and ceilings**

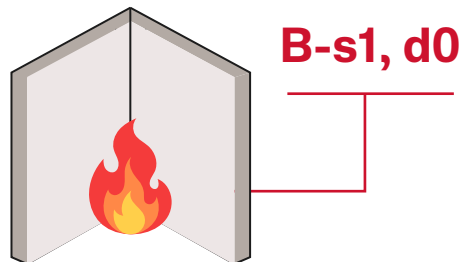

**Flooring**

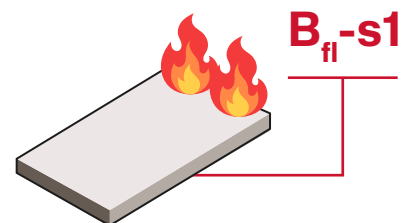

In the case of material applications such as flooring, the sub-index fl will be applied (*floor*) and it will not be necessary to evaluate the production of droplets and particles in flames.



# 03 / SuperPan® Tech

## The structural board for mezzanines



### Features



**High mechanical strength**  
High mechanical properties of flexural strength and high modulus for the most demanding situations.



**Omnidirectional**  
Equal resistance in any direction of the board. Optimized use.



**Good hold.**  
Excellent performance with fasteners such as screws, staples, or nails.



**Cutting perfection.**  
Achieve perfect board cuts, extending the lifespan of your cutting tools.



**Surface quality** The outer layer offers a smooth and compact fibre surface, ideal for any type of coating or paint (epoxy) applied directly.



**Tongue and groove option**  
Tongue-and-groove option for quick and easy assembly.



**Non-slip finish option**  
Option of anti-slip finishes that offer extra properties against slipperiness.



**Quick installation and good value for money.**  
It allows the use of thinner thicknesses compared to the use of traditional chipboard.

Due to its excellent physical and mechanical properties, SuperPan® Tech board is the ideal board for use in industrial mezzanines. SuperPan® Tech is an innovative board with a unique composition different from other conventional boards on the market. A new generation of technical wood manufactured by Finsa using a continuous pressing process.

## Composition and properties

By pressing the layers together, we obtain synergies that give the product great stability and high performance.

**Wood fiber:** Wood fibre layer that provides an excellent surface finish.

**Fine particle:** Fine particle layer that provides greater stability and helps to achieve a high-quality surface.

**Coarse particle:** Core made of large particleboard that provides structural strength.

This product configuration with a high density

gives it a load capacity far exceeding that of conventional mezzanine boards. In this application, this property is usually very advantageous in economic terms due to the spaces between beams that it allows to work with.

SuperPan® Tech also has a very wide range of qualities, adapting to all the specific needs of each project.

If we add to these advantages a white coating on the underside—which acts as a ceiling—it helps to create much brighter spaces, thus reducing energy consumption.

## Classifications

Depending on their physical-mechanical properties and the type of environment in which they can be used, SuperPan® Tech boards are classified according to EN 312 as:

Panels for interior applications in construction:

P4: Boards for structural applications in dry environments.

P5: Boards for structural applications in humid environments.

P6: High-performance boards for structural applications in dry environments.



# SuperPan®

A 100% versatile board.  
recyclable

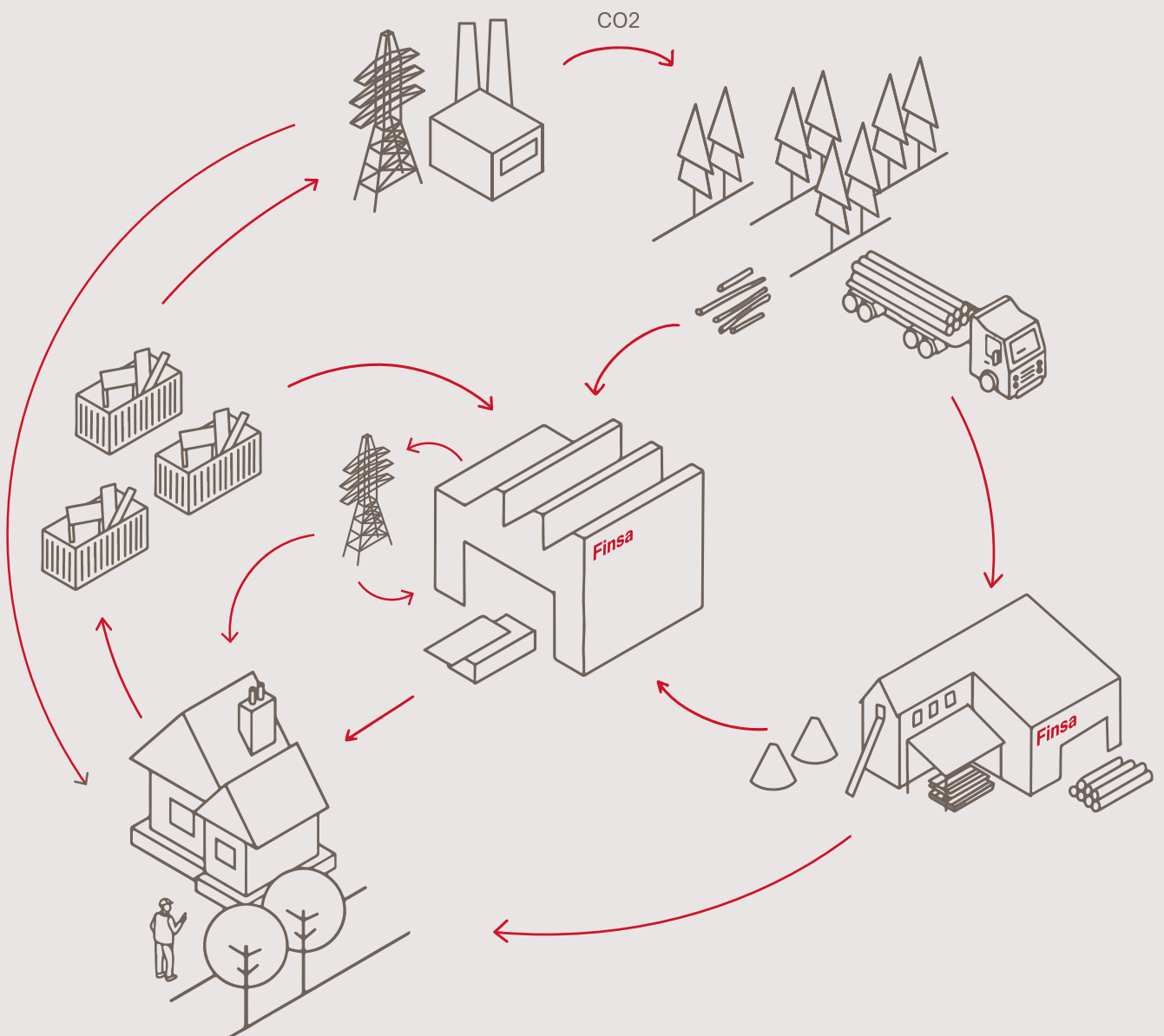

SuperPan® is a sustainable material that incorporates a high percentage of recycled wood in its composition and is 100% recyclable at the end of its useful life.

It is a board that contributes to the circular economy due to its reusable, renewable materials, which capture CO<sub>2</sub> and with low formaldehyde emissions.

It is made with locally sourced wood from certified and responsibly managed forests, with up to 40% recycled material that we give a new life to, betting on the circularity of the material and contributing to upcycling or *upcycling*.

### Wood from certified sources

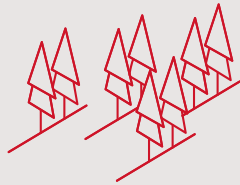

PEFC™ and FSC® | ISO 38200

### Certified recycled content



Recycled material content verified according to ISO 38200 and ISO 14021

### Net negative carbon footprint



The board retains more CO<sub>2</sub> than it emits during its production (EPD Certificate).  
-593 kg CO<sub>2</sub> equiv/ m<sup>23</sup>

### Local resources



Wood sourced from forests within 100 km of the plant.

Discover the complete technical data sheet and EPD.

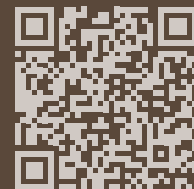

# 04/

# Availability



## SuperPan® Tech P6 EZ

P6 structural board made from wood, composed of wood fibre faces and particleboard interior, for use in dry environments.

Other options:

- Anti-slip surface finish (SA): rougher surface sanding to reduce slipperiness and improve adhesion of finishes.
- Tongue and groove TG2 and TG4 (on two or four sides).

Main features



Structural Use



EZ



Optional tongue and groove



Optional non-slip

- The SuperPan® Tech P6 EZ is a high-performance structural board, technical class P6, composed of wood fibre faces and a particleboard interior, suitable for dry environments. It has a smooth and compact fiber surface that accepts paint or direct coatings. A board of high mechanical resistance, not conditioned by the direction of the board. Allows for optimal screw or nail fastening.
- Classified P6 according to EN 312.
- Service class 1 .
- Formaldehyde emission: Class E05 .
- EZ: Low formaldehyde emission CARB2 / EPA according to American regulations.

Applications

Dry construction. Mezzanine and industrial shelving, floor construction. Rehabilitation and renovation of spaces. Raised access flooring.

Areas of use

Construction in residential, retail , and industrial sectors. Data centers.

Availability

Available in thicknesses between 30 and 40 mm.

Certifications





## SuperPan® Tech P6 EZ Decor

P6 structural board coated with decorative paper and composed of wood fibre faces and particleboard interior, for use in dry environments.

### Designs

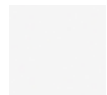

030 Blanco Super

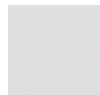

204 Gris I



13W Granitech

### Finished



Non-slip (AD)

For other decorative options, please consult our sales network.

— Raw on the surface Blanco Super on the flip side.

— Gris I Non-slip Blanco Super on the flip side.

— Granitech Non-slip Blanco Super on the flip side.

### Other options:

- Tongue and groove TG2 and TG4 (on two or four sides).
- Anti-slip finish (AD).

### Main features



Structural Use



EZ



Optional tongue and groove



Optional non-slip

- The SuperPan® Tech P6 EZ Decor is a board coated with decorative paper for structural use, technical class P6, composed of wood fibre faces and particleboard interior, suitable for dry environments. It has a smooth and compact fiber surface. It has high mechanical resistance, not conditioned by the direction of the board. It allows optimal fastening of screws or nails.
- Classified P6 according to EN 312.
- Service class 1 .
- Formaldehyde emission: Class E05 .
- EZ: Low formaldehyde emission CARB2 / EPA according to American regulations.

### Applications

Dry construction. Mezzanine and industrial shelving, floor construction. Rehabilitation and renovation of spaces. Raised access flooring.

### Areas of use

Construction in residential, retail , and industrial sectors. Data centers.

### Availability

Available in thicknesses between 30 and 40 mm.

### Certifications





**NEW**

## SuperPan® Tech P6 EZ Decor B

P6 structural board for mezzanines with improved fire reaction, coated with decorative paper and composed of wood fibre faces and particleboard interior, for use in dry environments.

Designs

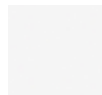

030 Blanco Super

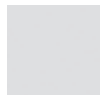

204 Gris I

Finished



Non-slip (AD)

For other decorative options, please consult our sales network.

—Gris I Non-slip Blanco Super on the flip side.

Other options:

- Tongue and groove TG2 and TG4 (on two or four sides).

### Main features



Structural



Ignifugo



EZ



Optional tongue and groove



Optional non-slip

- The SuperPan® Tech P6 EZ Decor B is a high-performance structural board, technical class P6, coated with decorative paper, specially designed for the construction of mezzanines and floors, offering improved fire reaction. This board is composed of wood fibre faces and a particleboard interior and is suitable for dry environments. It has a smooth and compact fiber surface. It is a high-strength mechanical board, not conditioned by the direction of the board. It allows for optimal screw or nail fastening.
- Fire reaction according to European standard EN 13501: Bfl-s1 (floor) and B-s2,d0 (ceiling), which makes it a safe and efficient solution for demanding structural applications.
- Classified P6 according to EN 312.
- Service class 1 .
- Formaldehyde emission: Class E05 .
- EZ: Low formaldehyde emission CARB2 / EPA according to American regulations.

### Applications

Dry construction. Mezzanine and industrial shelving, floor construction. Rehabilitation and renovation of spaces. Raised access flooring.

### Areas of use

Construction in residential, retail , and industrial sectors. Data centers.

### Availability

Available in thicknesses between 30 and 40 mm.

### Certifications





## SuperPan® Tech P5 EZ

P5 structural board made from wood composite, consisting of wood fibre faces and particleboard interior, for use in humid environments.

### Other options:

- Anti-slip surface finish (SA): rougher surface sanding to reduce slipperiness and improve adhesion of finishes.
- Tongue and groove TG2 and TG4 (on two or four sides).

### Main features



- The SuperPan® Tech P5 EZ is a P5 technical class structural board composed of wood fibre faces and a particleboard interior, suitable for humid environments. It features a smooth and compact fiber surface that accepts paint or direct coatings. It is a high-strength board whose mechanical resistance is not conditioned by the direction of the board, which facilitates its installation and use. It allows for optimal screw or nail fastening.
- It has a high level of airtightness (class A of the *Passivhaus Institute*) and exhibits good seismic performance in a light-frame wall.
- Classified P5 according to EN 312.
- Service class 2.
- Formaldehyde emission: Class E05 .
- EZ: Low formaldehyde emission CARB2 / EPA according to American regulations.
- Class A for the *Passivhaus Institute*.

### Applications

Dry construction. Lightweight and innovative framing systems, construction of walls, floors and roofs. Rehabilitation and renovation of spaces. Mezzanine and industrial shelving. Construction under the *Passivhaus* standard.

### Areas of use

Construction in residential, retail , and industrial sectors. Data centers.

### Availability

Available in thicknesses between 9 and 38 mm.

### Certifications





## SuperPan® Tech P5 EZ Decor

P5 structural board coated with decorative paper and composed of wood fibre faces and particleboard interior, for use in humid environments.

**Designs**

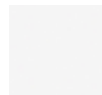

030 Blanco Super

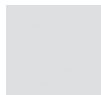

204 Gris I



13W Granitech

**Finished**



Non-slip (AD)

For other decorative options, please consult our sales network.

— Raw on the surface **Blanco Super** on the flip side.

— **Gris I Non-slip Blanco Super** on the flip side.

— **Granitech Non-slip Blanco Super** on the flip side.

Other options:

- Tongue and groove TG2 and TG4 (on two or four sides).
- Anti-slip finish (AD).

**Main features**



Structural Use



Water repellent



EZ



Optional tongue and groove



Optional non-slip

- The SuperPan® Tech P5 EZ Decor is a board coated with decorative paper for structural use, technical class P5, composed of wood fibre faces and a particleboard interior, suitable for humid environments. It has a smooth and compact fiber surface. It is a high-strength board, not conditioned by the direction of the board. It allows for optimal screw or nail fastening.
- Classified P5 according to EN 312.
- Service class 2.
- Formaldehyde emission: Class E05 .
- EZ: Low formaldehyde emission CARB2 / EPA according to American regulations.

**Applications**

Dry construction. Mezzanine and industrial shelving, floor construction. Rehabilitation and renovation of spaces. Raised access flooring.

**Areas of use**

Construction in residential, retail , and industrial sectors. Data centers.

**Availability**

Available in thicknesses between 9 and 38 mm.

**Certifications**





NEW

## SuperPan® Tech P5 EZ Decor B

P5 structural board for mezzanines with improved fire reaction, coated with decorative paper and composed of wood fibre faces and particleboard interior, for use in humid environments.

Designs



030 Blanco Super



204 Gris I

Finished



Non-slip (AD)

For other decorative options, please consult our sales network.

—Gris I Non-slip Blanco Super on the flip side.

Other options:

- Tongue and groove TG2 and TG4 (on two or four sides).

### Main features



Structural Use



Water repellent



Fire retardant



EZ



Optional tongue and groove



Optional non-slip

- SuperPan® Tech P5 EZ Decor B is a high-performance structural board, technical class P5, coated with decorative paper, specially designed for the construction of mezzanines and floors, offering improved fire reaction. This board is composed of wood fibre faces and a particle interior and is suitable for humid environments. It has a smooth and compact fiber surface. It is a product of high mechanical resistance, not conditioned by the direction of the board. It allows optimal fastening of screws or nails.
- Fire reaction according to European standard EN 13501: Bfl-s1 (floor) and B-s2,d0 (ceiling), which makes it a safe and efficient solution for demanding structural applications.
- Classified P5 according to EN 312.
- Service class 2.
- Formaldehyde emission: Class E05 .
- EZ: Low formaldehyde emission CARB2 / EPA according to American regulations.

### Applications

Dry construction. Mezzanine and industrial shelving, floor construction. Rehabilitation and renovation of spaces. Raised access flooring.

### Areas of use

Construction in residential, retail , and industrial sectors. Data centers.

### Availability

Available in 38 mm thickness.

### Certifications





## SuperPan® Tech P4 EZ

P4 structural board made from wood composite, consisting of wood fibre faces and particleboard interior, for use in dry environments.

Other options:

- Anti-slip surface finish (SA): rougher surface sanding to reduce slipperiness and improve adhesion of finishes.
- Tongue and groove TG2 and TG4 (on two or four sides).

Main features

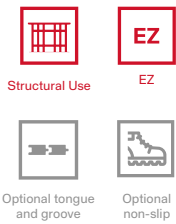

- The SuperPan® Tech P4 EZ is a P4 technical class structural board composed of wood fibre faces and a particleboard interior, suitable for dry environments. It features a smooth and compact fiber surface that accepts paint or direct coatings. It is a high-strength board, not conditioned by the direction of the board. It allows for optimal screw or nail fastening.
- Classified P4 according to EN 312.
- Service class 1 .
- Formaldehyde emission: Class E05 .
- EZ: Low formaldehyde emission CARB2 / EPA according to American regulations.

Applications

Dry construction. Mezzanine and industrial shelving, floor construction. Rehabilitation and renovation of spaces. Raised access flooring.

Areas of use

Construction in residential, retail , and industrial sectors. Data centers.

Availability

Available in thicknesses between 16 and 44 mm.

Certifications





## SuperPan® Tech P4 EZ Decor

P4 structural board coated with decorative paper and composed of wood fibre faces and particleboard interior, for use in dry environments.

### Designs

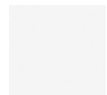

030 Blanco Super

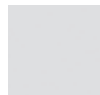

204 Gris I



13W Granitech

### Finished



Non-slip (AD)

For other decorative options, please consult our sales network.

— Raw on the surface **Blanco Super** on the flip side.

— **Gris I Non-slip Blanco Super** on the flip side.

— **Granitech Non-slip Blanco Super** on the flip side.

### Other options:

- Tongue and groove TG2 and TG4 (on two or four sides).
- Anti-slip finish (AD).

### Main features



Structural Use



EZ



Optional tongue and groove



Optional non-slip

- The SuperPan® Tech P4 EZ Decor is a board coated with decorative paper for structural use, technical class P4, composed of wood fibre faces and particleboard interior, suitable for dry environments. It has a smooth and compact fiber surface. It is also a board with high mechanical resistance, not conditioned by the direction of the board. It allows for optimal screw or nail fastening.
- Classified P4 according to EN 312.
- Service class 1 .
- Formaldehyde emission: Class E05 .
- EZ: Low formaldehyde emission CARB2 / EPA according to American regulations.

### Applications

Dry construction. Mezzanine and industrial shelving, floor construction. Rehabilitation and renovation of spaces. Raised access flooring.

### Areas of use

Construction in residential, retail, and industrial sectors. Data centers.

### Availability

Available in thicknesses between 16 and 40 mm.

### Certifications





## SuperPan® Tech P4 IGN EZ

P4 structural board made from wood composite, consisting of wood fibre faces and particleboard interior with improved fire resistance, for general use in dry environments.

Other options:

- Tongue and groove on two or four sides (TG2 and TG4).

### Main features



- The SuperPan® Tech P4 IGN EZ is a P4 technical class structural board composed of wood fibre faces and a particleboard interior with improved fire resistance (B-s1,d0 / B-s2,d0), suitable for general use in dry environments. It has a smooth and compact fiber surface that accepts paint or direct coatings. A high-strength board, not conditioned by the board's direction. Allows for optimal screw or nail fastening.
- Fire reaction according to EN 13501: B-s1,d0 from 12mm and B-s2,d0 for thicknesses less than 12 mm.
- Classified P4 according to EN 312.
- Service class 1 .
- Formaldehyde emission: Class E05 .
- EZ: Low formaldehyde emission CARB2 / EPA according to American regulations.

### Applications

Dry construction. Mezzanine and industrial shelving, floor construction. Rehabilitation and renovation of spaces. Raised access flooring. Innovative construction systems.

### Areas of use

Construction in residential, retail , and industrial sectors. Data centers.

### Availability

Available in thicknesses between 8 and 38 mm.

### Certifications





## SuperPan® Tech P4 IGN EZ Decor

P4 structural board coated with decorative paper and composed of wood fibre faces and particleboard interior with improved fire resistance, for general use in dry environments.

Designs

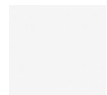

030 Blanco Super

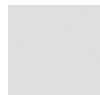

204 Gris I



13W Granitech

Finished



Non-slip (AD)

—Gris I Non-slip Blanco Super on the flip side.

—Granitech Non-slip Blanco Super on the flip side.

SuperPan® Tech P4 IGN EZ Decor is only available with double-sided decorative paper.

For other decorative options, please consult our sales network.

Other options:

- Tongue and groove on two or four sides (TG2 and TG4).

Main features



Structural Use



Fire retardant



EZ



Optional tongue and groove



Optional non-slip

- The SuperPan® Tech P4 EZ Decor is a board coated with decorative paper for structural use, technical class P4, composed of wood fibre faces and a particleboard interior, suitable for dry environments. It has a smooth and compact fiber surface. Furthermore, it is a board with high mechanical resistance, not conditioned by the direction of the board. It allows for optimal screw or nail fastening.
- Classified P4 according to EN 312.
- Service class 1 .
- Formaldehyde emission: Class E05 .
- EZ: Low formaldehyde emission CARB2 / EPA according to American regulations.

Applications

Dry construction. Mezzanine and industrial shelving, floor construction. Rehabilitation and renovation of spaces. Raised access flooring. Innovative construction systems.

Areas of use

Construction in retail , commercial, and industrial sectors. Data centers.

Availability

Available in thicknesses between 8 and 38 mm.

Certifications



Scan the QR code and access our website and comprehensive service programs.



---

### Service program

In this service program, you will find information about our offerings, available references for packaging and panels from the unit included in our ranges, including the areas of Finsa Design, Finsa Tech, and Finsa Process.

---

Discover more availability guides on our website.

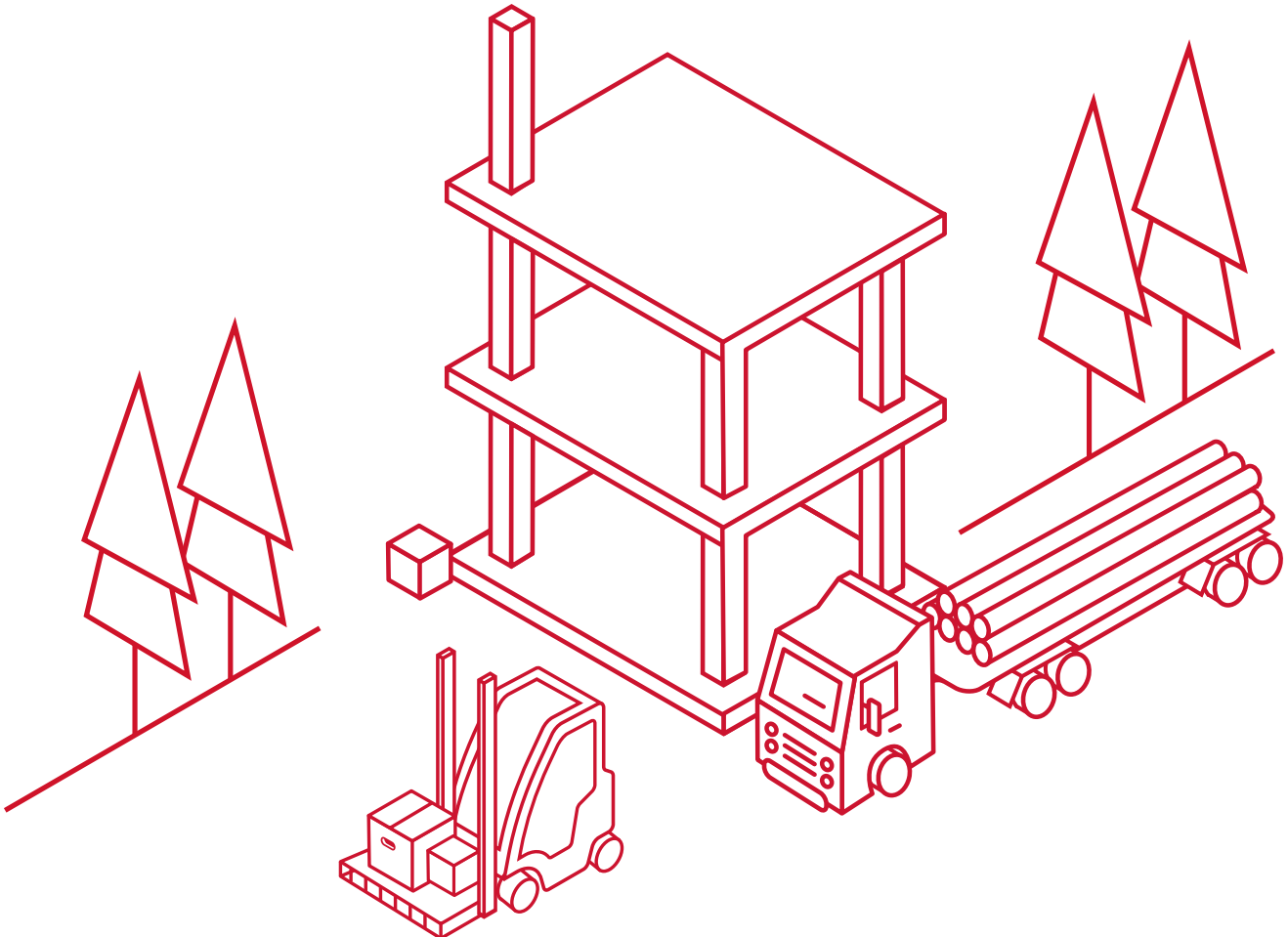

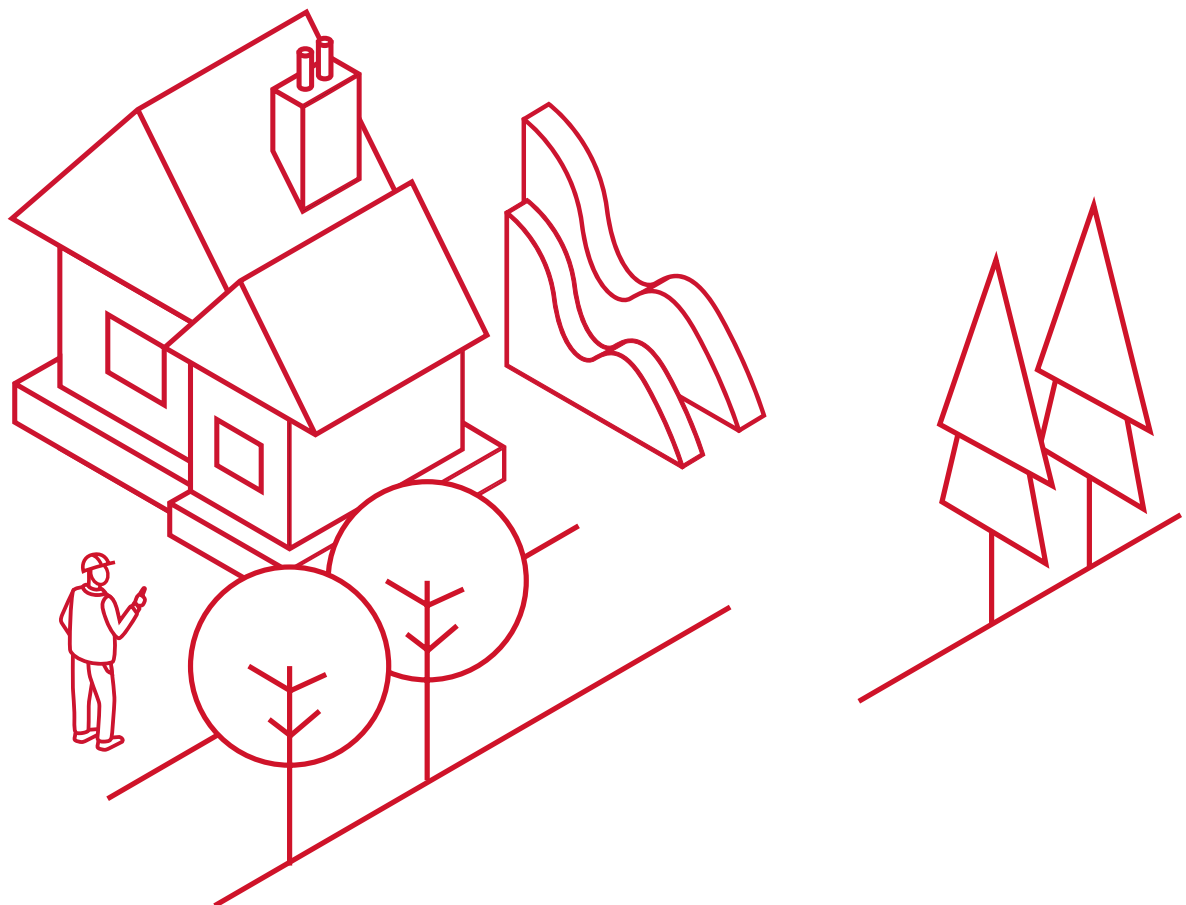

# 05/ Technical information

## 5.1 Offer characteristics

P6 Service class 1	Fire reaction	Anti-slip	Abrasion resistance	Antistatic	Antibacterial	TG2	TG4
						Tongue and groove	
SuperPan® Tech P6 EZ	D-s2, d0					YES	YES
	Dfl-s1						
SuperPan® Tech P6 EZ SA	D-s2, d0	R9				YES	YES
	Dfl-s1						
SuperPan® Tech P6 EZ Decor Blanco Super 1/side	Dfl-s1				NO	YES	YES
	D-s2, d0				YES Only bottom side Blanco Super		
SuperPan® Tech P6 EZ Decor Gris I AD / Blanco Super	Bfl-s1	R10		YES	YES	YES	YES
	D-s2, d0						
SuperPan® Tech P6 EZ Decor GraniTech AD / Blanco Super	Bfl-s1	R10	AC2 to AC5**	YES	YES	YES	YES
	D-s2, d0						
SuperPan® Tech P6 EZ Decor B Gris I AD / Blanco Super	Bfl-s1	R10	AC2 to AC5**	YES	YES	YES	YES
	Bs2, d0						

P5 Service class 2	Fire reaction	Anti-slip	Abrasion resistance	Antistatic	Antibacterial	TG2	TG4
						Tongue and groove	
SuperPan® Tech P5 EZ	D-s2, d0					YES	YES
SuperPan® Tech P5 EZ SA	D-s2, d0	R9				YES	SI
SuperPan® Tech P5 EZ Decor Blanco Super 1/side	Bfl-s1	R10			NO	YES	YES
	D-s2, d0				YES Only bottom side Blanco Super		
SuperPan® Tech P5 EZ Decor Gris I AD / Blanco Super	Bfl-s1	R10	AC2 to AC5**	YES	YES	YES	YES
	D-s2, d0						
SuperPan® Tech P5 EZ Decor B Gris I AD / Blanco Super	Bfl-s1	R10	AC2 to AC5**	YES	YES	YES	YES
	Bs2, d0						

## P4 Service class 1

	Fire reaction	Anti-slip	Abrasion resistance	Antistatic	Antibacterial	TG2	TG4
						Tongue and groove	
SuperPan® Tech P4 EZ	D-s2, d0					YES	YES
SuperPan® Tech P4 EZ SA	D-s2, d0	R9				YES	YES
SuperPan® Tech P4 EZ Decor Blanco Super 1/side	Dfl-s2				NO	YES	YES
	D-s2, d0				YES Only bottom side Blanco Super		
SuperPan® Tech P4 EZ Decor Gris I AD / Blanco Super	Bfl-s1	R10	AC2 to AC5**	YES	YES	YES	YES
	D-s2, d0						
SuperPan® Tech P4 EZ Decor GraniTech AD / Blanco Super	Bfl-s1	R10	AC3 to AC5**	YES	YES	YES	YES
	D-s2, d0						
SuperPan® Tech P4 IGN EZ	B-s1, d0*					YES	YES
	Bfl-s1						
SuperPan® Tech P4 IGN EZ Decor Gris I AD / Blanco Super	Bfl-s1	R10	AC2 to AC5**	YES	YES	YES	YES
	B-s1, d0						

\* For thicknesses greater than 12 mm B-s1, d0. Less than 12 mm B-s2, d0. \*\* AC6 also available upon request.

— Check offer with the sales network.

Legend:

SA - Anti-slip Surface AD - Anti-slip

## fire-retardant structural board

### Class B

A fire-resistant and wear-resistant top layer with Bfl-s1 classification combined with a white fire-resistant bottom layer with B-s2,d0 classification create a fire-retardant structural board specially designed for mezzanine floors.

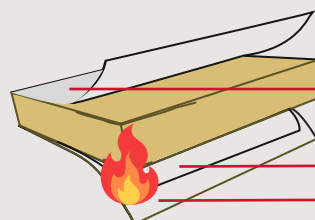

Decorative non-slip finish,  
Gris I

Special fire-retardant film,  
class B  
Super Blanco Decorative Finish

## 5.2 Structural data

### Pre-sizing of floor slabs for mezzanines

The entire SuperPan® Tech board range is structurally characterized according to standard EN 789, the values of which can be found in this table.

Propiedad	Tipo tablero	SuperPan® Tech P6 EZ		SuperPan® Tech P5 EZ					SuperPan® Tech P4 EZ				Unidad
	Espesor (mm)	25 a 32	32 a 40	6 a 13	13 a 20	20 a 25	25 a 32	32 a 40	13 a 20	20 a 25	25 a 32	32 a 40	
<b>Resistencia característica</b>													
Flexión	$f_{m,k}$	20,87	16,53	21,18	22,12	22,54	22,41	22,27	19,44	19,05	18,66	19,34	N/mm <sup>2</sup>
Tracción	$f_{t,0,k}$	10,15	8,77	11,60	10,23	10,32	10,47	10,69	7,33	8,21	8,84	9,54	N/mm <sup>2</sup>
Compresión	$f_{c,90,k}$	3,47	3,41	4,18	3,81	3,70	3,53	3,34	4,04	3,90	3,63	3,07	N/mm <sup>2</sup>
Cortante de cizalladura, en el grueso	$f_{v,k}$	6,76	5,56	7,63	7,77	7,48	7,07	6,60	6,70	6,49	6,27	6,19	N/mm <sup>2</sup>
Cortante de rodadura, en el plano	$f_{v,k}$	1,86	1,51	1,51	1,73	1,75	1,65	1,52	1,58	1,63	1,52	0,81	N/mm <sup>2</sup>
<b>Rigidez media - Módulos de elasticidad medios</b>													
Flexión	$E_{m,0,mean}$	3475	3424	3824	4025	3872	3599	3281	3207	3157	3137	3412	N/mm <sup>2</sup>
Tracción	$E_{t,0,mean}$	2158	2041	2463	2411	2305	2176	2027	1717	1831	1948	2132	N/mm <sup>2</sup>
Compresión perpendicular	$E_{c,90,mean}$	157	147	208	174	157	144	129	109	114	118	115	N/mm <sup>2</sup>
Cortante de cizalladura	$G_{v,mean}$	903	860	981	1010	968	901	823	799	816	832	851	N/mm <sup>2</sup>
Cortante de rodadura	$G_{r,mean}$	246	231	230	286	283	261	235	211	211	210	203	N/mm <sup>2</sup>
<b>Densidad</b>													
Densidad característica	$\rho_k$	597	578	640	633	619	600	579	617	599	581	578	kg/m <sup>3</sup>
<b>Densidad media</b>	$\rho_m$	<b>672</b>	<b>657</b>	<b>717</b>	<b>712</b>	<b>698</b>	<b>680</b>	<b>659</b>	<b>702</b>	<b>678</b>	<b>657</b>	<b>650</b>	<b>kg/m<sup>3</sup></b>

These values have been obtained from a statistical study based on the structural characterization tests carried out at PEMADE, an ENAC-accredited laboratory, according to EN 789:2006 for the boards SuperPan® Tech P4 EZ in thicknesses 18, 30 and 38 mm; SuperPan® Tech P5 EZ in 12, 18 and 35 mm and SuperPan® Tech P6 EZ in 30, 38, and 40 mm thicknesses.

**Disclaimer** The conditions for placing the deck in position SuperPan® Tech are unknown. In no case does Finsa (FINANCIERA MADERERA, SA), nor its representatives, have knowledge of the quality of the materials, the construction methods used in the construction project, and the experience of the agents involved. Therefore, in accordance with this, they do not guarantee the technical data, the calculation, or the execution of the SuperPan® Tech board in its complete structures. FINANCIERA MADERERA, SA is not responsible for damages resulting from not following these recommendations, or for product failures caused by an inadequate structural design or by the misuse of this product.

## Comparison of values

The SuperPan® Tech P4 values shown in the graphs are the result of tests carried out at PEMADE according to UNE-EN 789:2006 Timber structures. Test methods. Determination of the mechanical properties of wood-based panels.

The values for P4 Structural Particleboards are values taken from UNE-EN-12369-1-2001 Wood-based panels. Characteristic values for structural design.

### Comparative table of properties SuperPan® Tech P6 EZ vs. Chipboard P6

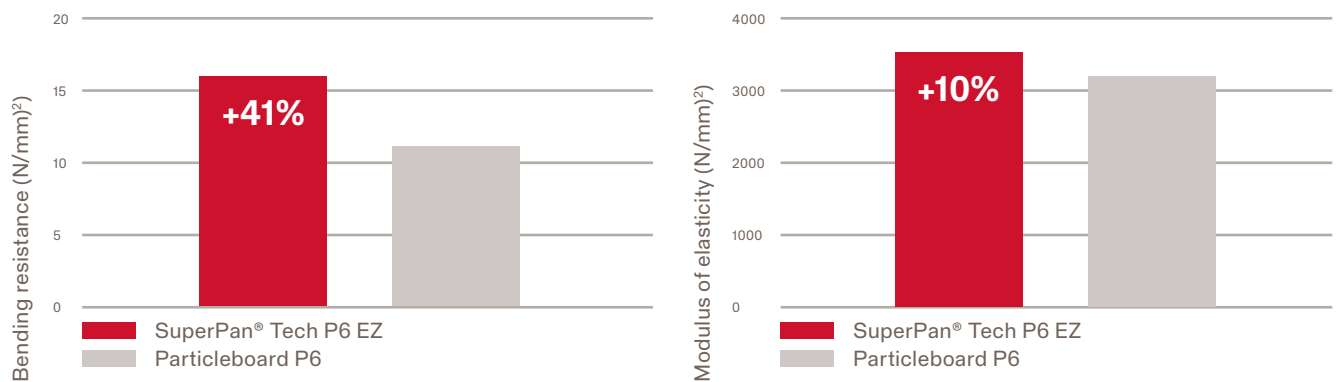

### Comparative table of properties SuperPan® Tech P5 EZ vs. P5 Chipboard

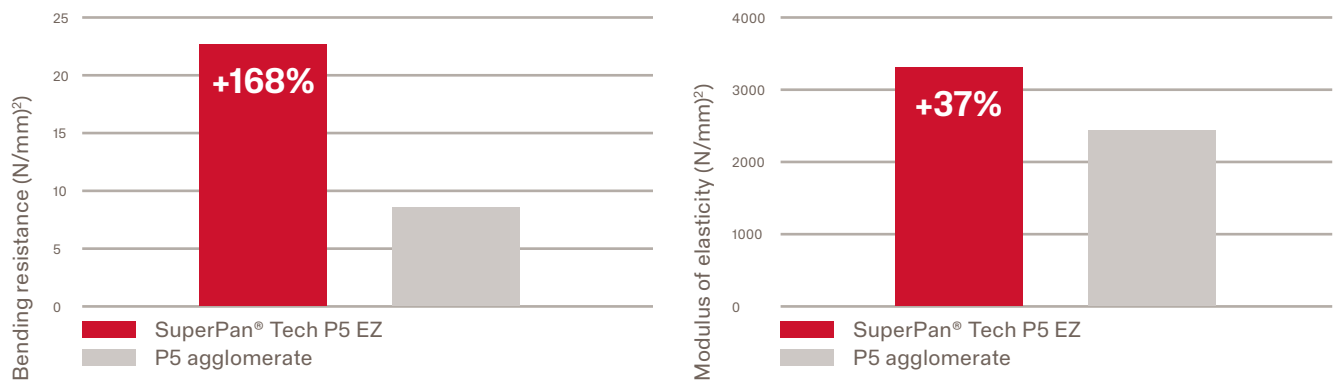

### Comparative table of properties SuperPan® Tech P4 EZ vs. P4 Chipboard

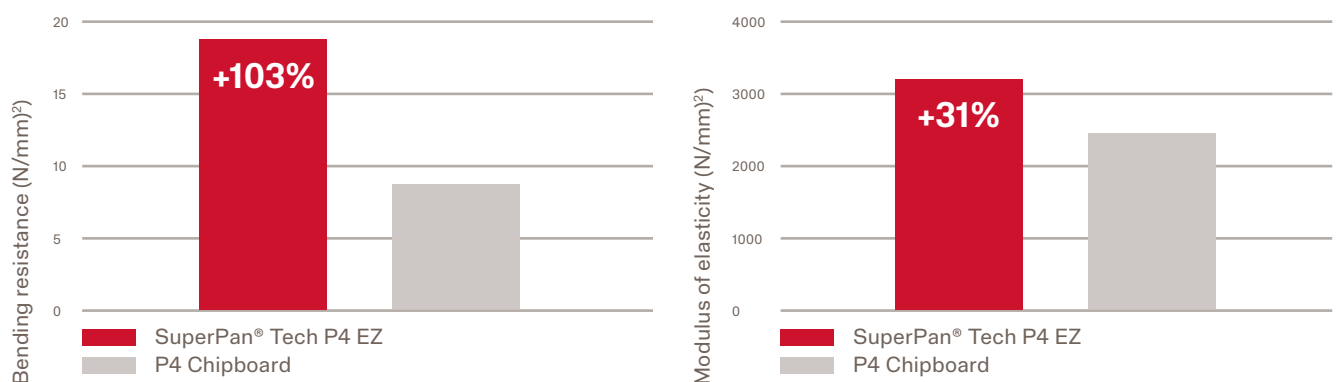

---

## Pre-calculations tool for boards

We have a platform you can use to perform structural calculations for panels according to the regulations of the Technical Building Code (CTE) and the Eurocode. With this tool, you can evaluate specific cases of pre-dimensioning of floor slabs, pitched roofs with rafters or purlins, and adapt them to the characteristics of your project. Through our website, you can access the tool to enter the necessary data and obtain a structural analysis of SuperPan® Tech panels in various applications. Its design facilitates both data entry and the interpretation of results. This tool is designed so that, as a professional in the construction sector, whether an engineer or architect, you can perform structural calculations in compliance with current regulations. If you have any questions or need additional information about its use, do not hesitate to consult our technical team. We are available to help you get the most out of SuperPan® Tech.



Access the floor calculator.

<https://forgedcalculation.finsa.com/>

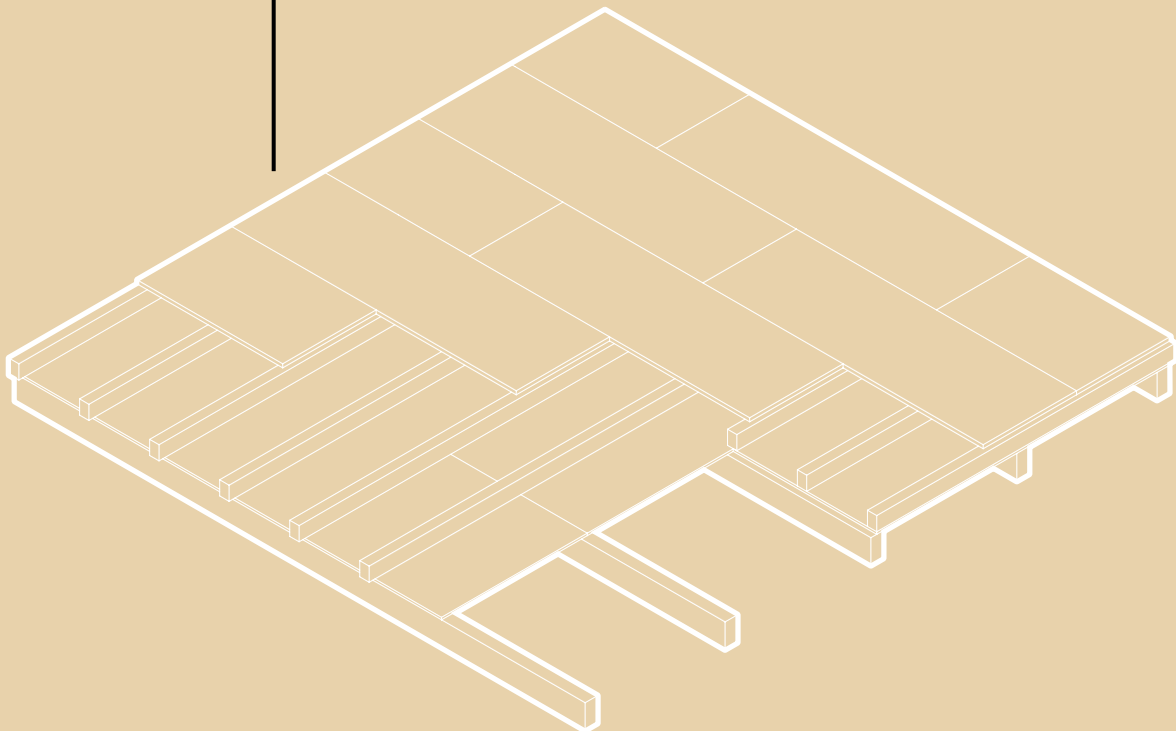



## Structural behavior report

### Structural behavior under uniformly distributed loads

All loads are considered uniformly distributed. The maximum load capacity has been estimated based on: EN 1990 and EN 1995 standards; Service class 1 or 2; two or more equal spans;  $K_{sys} = 1.1$ ; Storage areas; Long duration. Fire resistance is not considered.

- Deformation criterion  $L/100$ ; 6mm, in which a deformation in the center of the span of a maximum of  $L/100$  is allowed, where L is the span length with a maximum of 6 mm.
- Deformation criteria of  $L/200$ ; 3 mm, in which a deformation in the center of the span of a maximum of  $L/200$  is allowed, where L is the span length, with a maximum of 3 mm.

<b>SuperPan® Tech P6 EZ 38 mm</b>							
	Uniformly Distributed Loads (kN/m²)						
	Service Class 1						
	Support Spacing (mm)	400	500	525	600	700	800
Long term. Min (L/100; 6mm)	42,5	34	32,2	24,6	18	13,6	10,8
Long term. Min (L/200; 3mm)	42,5	34	32,2	24,6	17,7	10,2	6,2
Long term. Min (L/300)	42,5	34	32,2	21,9	13,7	9	6,2

<b>SuperPan® Tech P5 EZ 38 mm</b>			
	Uniformly Distributed Loads (kN/m²)		
	Service Class 2		
	Support Spacing (mm)	400	600
Long term. Min (L/100; 6mm)	38,1	25,3	14,9
Long term. Min (L/200; 3mm)	38,1	25,3	10
Long term. Min (L/300)	38,1	21,7	8,8

<b>SuperPan® Tech P5 EZ 38 mm</b>			
	Uniformly Distributed Loads (kN/m²)		
	Service Class 2		
	Support Spacing (mm)	400	600
Long term. Min (L/100; 6mm)	25,3	16,7	10,9
Long term. Min (L/200; 3mm)	25,3	16,7	5,7
Long term. Min (L/300)	25,3	12,7	5,0

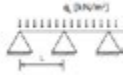
<b>SuperPan® Tech P4 EZ 30 mm</b>			
	Uniformly Distributed Loads (kN/m²)		
	Service Class 1		
	Support Spacing (mm)	400	600
Long term. Min (L/100; 6mm)	30	15,4	6,8
Long term. Min (L/200; 3mm)	30	11	3,1
Long term. Min (L/300)	25,5	7,2	2,7

Structural behavior report

**Structural behavior under point load**

The permitted design load is the smallest load in each column, taking into account the design limitations. All point load values are determined using a 50 x 50 mm load plate in accordance with EC1, EC5, EN 1195:1998, ANE EN 12871:2013. All values are recorded in kN and mm. The results are calculated according to the following criteria: Service class 1, the maximum permitted deformation is set at the minimum of L/100 or 6 mm for all spans.  $\gamma_m = 1.30$ ;  $\gamma_q = 1.35$  for permanent loads and 1.5 for imposed loads;  $k_{red} = 0.67$ ;  $k_{dis} = 1$ ;  $\Psi_2 = 0.8$  (storage areas);  $\Psi_2 = 0.6$  (meeting places and shops);  $\Psi_2 = 0.3$  (Residential and office areas).

For Superpan® Tech,  $k_{mod}$  values of 0.5, 0.7, and 0.9 are used for long-term, medium-term, and short-term duration loads, respectively, with  $k_{def} = 1.5$ .

The duration of the charge is defined according to EC5: long duration - from 6 months to 10 years, medium duration - from 1 week to 6 months, short duration - less than 1 week.

Minimum loading area equal to or greater than a square with sides of 50 mm.

<b>SuperPan® Tech P6 EZ</b>					
Point Loads (kN)					
					
Thickness (mm)	Support spacing (mm)				
	400	600	750	800	850
Service Class 1					
<b>Industrial Storage (<math>\Psi_2=0,80</math>)</b>					
Long term (6 months to 10 years) ( $k_{mod}=0,50$ )					
30	3,58	3,44	-	2,26	-
38	4,32	4,75	4,15	3,97	3,19
<b>Assembly Areas and Commercial Premises (<math>\Psi_2=0,6</math>)</b>					
Medium term (1 week to 6 months) ( $k_{mod}=0,70$ )					
30	5,01	4,82	-	2,62	-
38	6,05	5,98	4,80	4,72	4,59
<b>Residential Areas and Offices (<math>\Psi_2=0,3</math>)</b>					
Medium term (1 week to 6 months) ( $k_{mod}=0,70$ )					
30	5,01	4,82	-	3,43	-
38	6,05	6,64	5,94	5,56	4,84

**SuperPan® Tech P5 EZ**

Point Loads (kN)



Thickness (mm)	Support spacing (mm)		
	400	600	800

Service Class 2

**Industrial Storage ( $\Psi_2=0,80$ )**Long term (6 months to 10 years) ( $k_{mod}=0,50$ )

35	4,57	4,18	3,63
38	5,44	3,93	3,85

**Assembly Areas and Commercial Premises ( $\Psi_2=0,6$ )**Medium term (1 week to 6 months) ( $k_{mod}=0,70$ )

35	6,4	5,85	4,2
38	7,61	5,51	4,45

**Residential Areas and Offices ( $\Psi_2=0,3$ )**Medium term (1 week to 6 months) ( $k_{mod}=0,70$ )

35	6,4	5,45	5,4
38	7,61	5,51	5,83

**SuperPan® Tech P4 EZ**

Point Loads (kN)

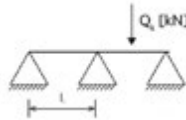

Thickness (mm)	Support spacing (mm)		
	400	600	800

Service Class 1

**Industrial Storage ( $\Psi_2=0,80$ )**Long term (6 months to 10 years) ( $k_{mod}=0,50$ )

30	2,95	3,35	2,1
38	4,93	4,52	3,57

**Assembly Areas and Commercial Premises ( $\Psi_2=0,6$ )**Medium term (1 week to 6 months) ( $k_{mod}=0,70$ )

30	4,14	4,69	2,43
38	6,9	6,33	4,14

**Residential Areas and Offices ( $\Psi_2=0,3$ )**Medium term (1 week to 6 months) ( $k_{mod}=0,70$ )

30	4,14	4,69	3,19
38	6,9	6,33	5,42

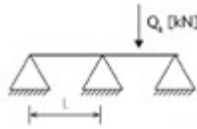
<b>SuperPan® Tech P4 EZ IGN</b>			
Point Loads (kN)			
			
Thickness (mm)	Support spacing (mm)		
	400	600	800
Service Class 1			
<b>Industrial Storage (<math>\Psi_2=0,80</math>)</b>			
Long term (6 months to 10 years) ( $k_{mod}=0,50$ )			
30	2,88	2,28	1,51
35	2,9	2,31	1,51
38	4,06	3,63	3,35
<b>Assembly Areas and Commercial Premises (<math>\Psi_2=0,6</math>)</b>			
Medium term (1 week to 6 months) ( $k_{mod}=0,70$ )			
30	4,16	3,3	1,79
35	4,19	3,34	1,79
38	5,68	5,08	3,88
<b>Residential Areas and Offices (<math>\Psi_2=0,3</math>)</b>			
Medium term (1 week to 6 months) ( $k_{mod}=0,70$ )			
30	4,16	3,3	2,52
35	4,19	3,34	2,52
38	5,68	5,08	5,09

For more information about testing, or to obtain point load test results using specific distances, contact Finsa 's technical office.

The data in this document is based on values verified through technical tests carried out in laboratories at the University of Coimbra and at PEMADE. For the initial design prior to using the product, it is recommended that a qualified technician perform the appropriate calculations to establish the suitability of the material for each application.

FINANCIERA MADERERA, SA is not responsible for the use of the data shown in this report.





## 5.3 General Recommendations

Proper board storage and packaging prevents undesirable deformations, and helps preserve flatness .

### Transportation, Storage & Handling

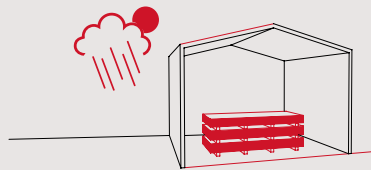

The boards must be transported and stored carefully, in compact stacks and resting on a suitable flat base. Check that the spacers are placed in the same position and aligned to prevent deformation of the board.

We recommend keeping the boards in their original packaging, always in a dry place, protected from contact with the ground, walls, and moisture. Special attention should be paid to sharp impacts and falls of the board to the ground, as it may be damaged internally.

- The boards must always be stored under cover and on a flat surface.
- The optimal storage conditions are 65% humidity, avoiding drier or more humid environments.
- Under no circumstances should there be direct contact with the water.
- The studs should always be aligned with the vertical.
- It is not recommended to stack more than four packages.
- If the packaging is damaged during handling, it must be re-packaged to ensure the product is properly preserved.
- Conditioning to the application site is advised so that the boards adapt to the ambient temperature and humidity conditions. A minimum conditioning period of 72 hours is recommended.
- Failure to respect the indicated stacking conditions, as well as changes in humidity or temperature in warehouses or processing areas, can cause irreversible deformations and curvatures.

### Machining & Cutting

The working conditions (speed, pressure, and temperature) of the cutting and machining processes are similar to those normally used. The edges must be protected against impacts, shocks, wear, and moisture.



## Technical specifications

Visit our website  
and consult the  
technical data  
sheets of our  
products.



## 5.4 Installation Recommendations

### Leveling support structure

The support structure (metal or wood) on which the boards will be placed must be perfectly level.

Differences in level within the structure can create steps between the boards, increasing wear and tear on the pieces and the risk of tripping.

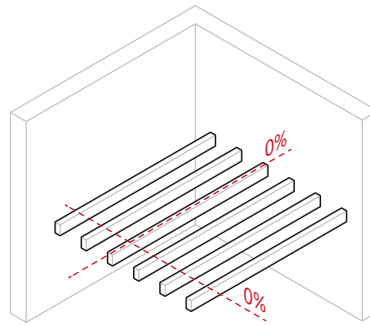

### Placement

Tongue-and-groove boards must be placed perpendicular to the direction of the beams on which they rest.

Therefore, the joints of the shorter sides should be staggered and always rest on the beams.

The straight-edged boards will be continuously supported on all four sides, with their shorter sides resting on the wooden or steel joists (with the fastening varying according to project specifications) and the longer sides on the crossbeams or joint covers.

The joist must allow the edge of the board to be supported by at least 18 mm and separate the screws from the edge of the board by at least 8 mm.

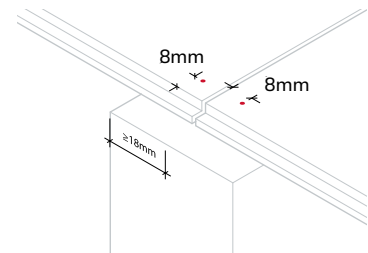
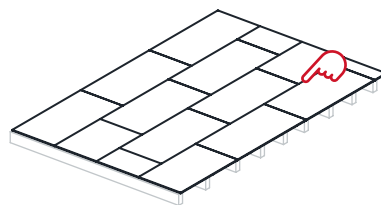

## Expansion board

An expansion joint will be left to allow for movement due to variations in moisture content. In straight-edged panels, a 3-5 mm gap should be left between panels.

In tongue-and-groove boards, this joint is not necessary since the tongue-and-groove configuration itself leaves a separation joint.

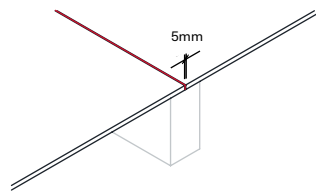

The separation between the heads should be 3-5 mm.

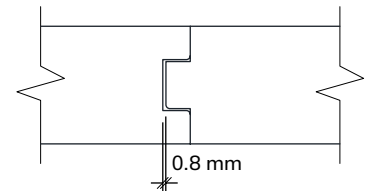

Joint flush. The tongue and groove joint of the 30 mm thick SuperPan® Tech TG4 leaves a 0.8 mm gap.

In panels with a tongue-and-groove system, it is recommended to leave a gap around the perimeter of the floor slab enclosure to allow for possible expansion due to moisture migration from building elements with which they are in contact.

It is recommended to leave the joints free and covered by a skirting board or filled with a compressible strip of a material such as cork or insulating fiberboard.

For large-span floor slabs, with a length greater than 7 m, intermediate expansion joints may be necessary.

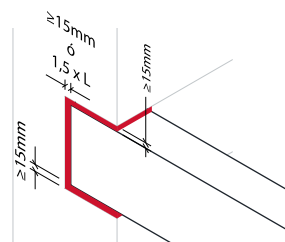

Always leave a perimeter clearance and with through-elements of 15mm or 1.5xL(m).

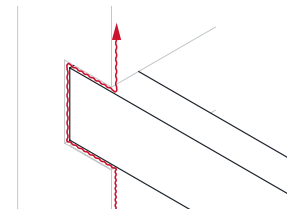

It is recommended to allow ventilation of all wooden elements, leaving a separation of at least 15mm in the beam supports and joists.

It is recommended to leave a clearance of at least 10 mm on each side of the slab perimeter, or 1.5 mm L.

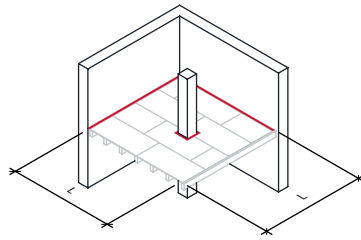

Always leave a perimeter clearance and with through-hole elements of 10mm x 1.5xL(m).

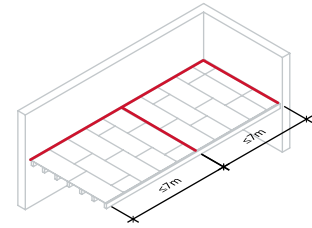

When the slab panels are larger than 7m, intermediate expansion joints of 1.5mm x L (span length) must be provided.

## Glued

All joints between the tongue-and-groove floorboards will be glued with a suitable PVAC D4 adhesive or equivalent, in order to prevent the appearance of noise during use. The use of adhesives in the joints also helps to increase the rigidity of the floor against vibrations, reduce the appearance of cracks derived from the expansion of the material after its placement, and decrease the effect of footfall during transit.

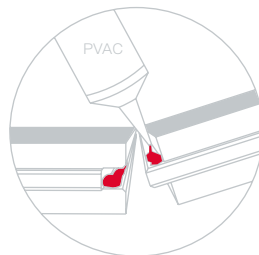

## Fixation

Preferably, ring-shank or helical-shank nails or screws with flat heads, or other improved types with superior anchoring capacity and corrosion resistance for service class 2, will be used.

If the board is to be fixed to a metal structure, it is advisable to use slotted head, self-drilling and self-tapping screws.

The minimum length of the nails or screws shall be 50 mm or 2 times the thickness of the board.

They should be recessed between 2 and 3 mm from the surface of the board.

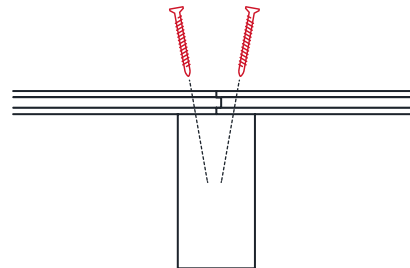

The lag screws will be placed with a slight inclination towards the head of the board.

The fastening method, size, and arrangement should be consulted with the hardware manufacturer.

Unless different separations or distributions are required by calculation, it is advised to:

### Maximum separation of the fixings (mm)

Distance between fixings on the perimeter of the panels	Distance between fixings on the intermediate supports of the boards	Minimum distance from the edge of the board (mm)
150	300	8

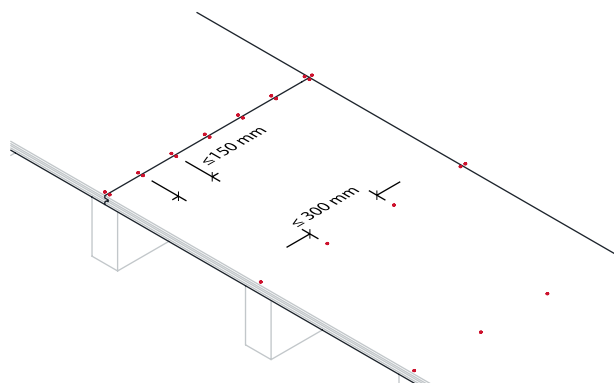

---

## Watertightness

If working conditions require a waterproof floor, it is necessary to apply adhesive directly to the male and female joints of the profile, along the entire length of each board. It is essential to ensure that the joints are completely sealed by firmly pressing the boards together. When joining them, the adhesive should protrude slightly in the form of foam from the board joint. Excess adhesive should be allowed to dry completely. If any joint is

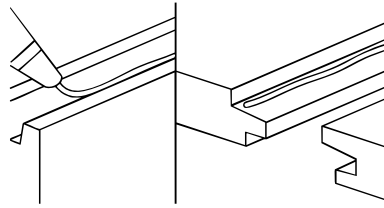

not properly sealed and no adhesive is visible, it will be necessary to reapply the product to ensure proper watertightness. The adhesives recommended for this process are: PVA D4, Acidic Silicone and PUR D4. These products have been validated through external tests with a duration of 60 days.

## Cleaning , maintenance, and repair

When cleaning with water is planned for industrial floors with a decorative finish, it is essential to seal the joints (tongue and groove), as contact with water can damage the joints between the panels. If this sealing is not carried out or if uncoated boards are used, the use of water for cleaning and maintaining the floor is not recommended. In case of superficial damage, it is advisable to repair using specific floor putties. If the damage is only aesthetic and shallow, touch-up pens of the appropriate colour can also be used for a visual repair.

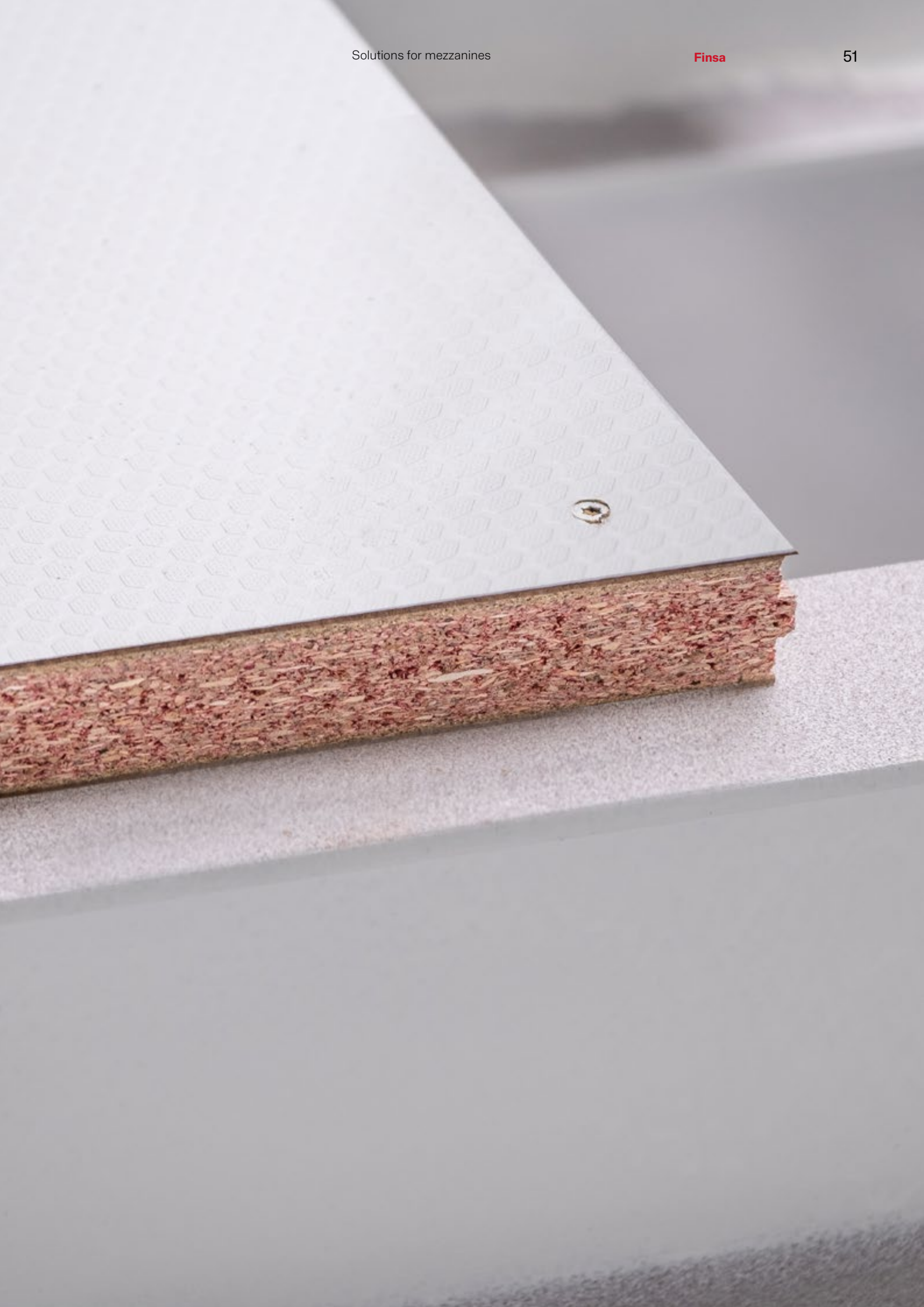

# 06/ Other documents

---

AIDIMME  
SuperPan® Tech  
Study -35 °C

Evaluation of the behavior of SuperPan® Tech board under extreme cold conditions (-35 °C) for use in industrial mezzanines in cold storage rooms.

---

AIDIMME Study:  
Joint Sealing

Test of water resistance and behavior of the sealed tongue-and-groove joint in applications with frequent water cleaning.

---

Class B  
Certification (fire  
reaction)

Fire resistance certificates in class B-s1, d0 in accordance with European standards for use in raised floors and applications with high fire safety requirements.

## Finsa

Maderera Finacial SACentral Services  
N-550 Highway, km. 57 15707 Santiago  
de Compostela A Coruña Spain Tel.:  
+34 981 05 00 00 e-mail: f-santiago@  
finsa.es

Product design and development:  
Finsa 's technical and design team

Design and layout:  
Finsa 's marketing team

Photograph:

The photographs appearing on the cover and on pages 2, 8, 11, 12 , 14, 15, 43 and 51 correspond to the project of an industrial mezzanine in a warehouse of a fruit and vegetable company in El Ejido (Almería) carried out by Instalaciones Mecánicas Emilio Gea.

The photograph that appears on pages 44-45 corresponds to the Iberostar Fuerteventura Palace project carried out by Galvanálisis.

### IMPORTANT

Photographs may not accurately represent the colours and finishes of the materials. Please refer to the current price list at the time of purchase.

Consult with our Consulting team for specific projects.

© Copyright 2025. FINANCIERA  
MADERERA SA

All rights reserved. Total or partial reproduction of this catalogue by any means is prohibited without the prior written authorization of FINANCIERA MADERERA SA.

# Finsa

