

Fintop Xtrim

Worktop joining kit

Ultra-slim hardware for thin worktops

MAIN FEATURES

- Compatible with Fintop Xtrim worktops.
- Valid for other products that allow a minimum machining depth of 9 mm.
- Concealed joint system with double moon and metric thread screw.
- Screw with a castellated head for tightening with a flat-head screwdriver.
- Supplied in boxes of 20 units, individually packaged.

SPECIFICATIONS

1x M5x60 screw with castle head

1x Half moon without screw thread

1x M5 threaded half moon washer

First, insert the moon without the screw with the flat side facing the head of the screw, then the threaded moon with the flat side of the screw facing outwards.

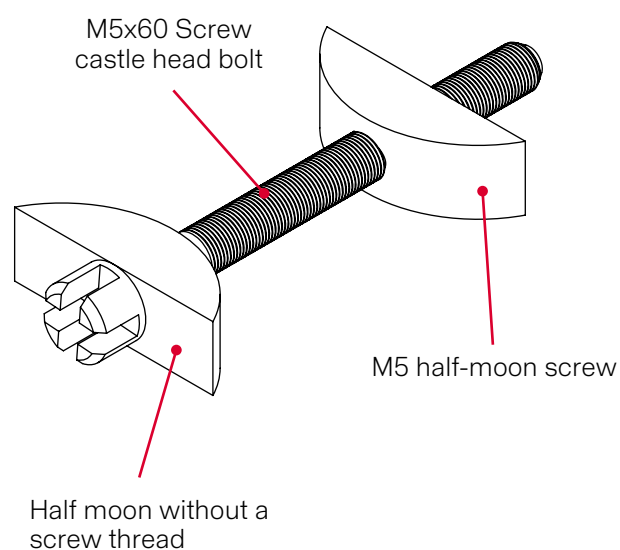

MECHANIZATION

By channel

(units in mm)

