

Finsa

Solutions for facades

2022



Finsa



Solutions for facades



1	Finsa	We are Finsa	9
		Finsa in numbers	11
		Sustainability	13
		Savia	15

2	Thermopine Savia	Facades with Thermopine Savia	19
		What is Thermopine Savia	20
		Heat treatment	21
		Categories	22
		Process Steps	23
		Properties	24
		Self-reported carbon footprint	26
		CTE DB SI Compliance	28
		Use class	28
		Range of claddings	31
		Standard façade profiles	32
		Installation accessories	35
		Cuts and finishing	36
		Quality criteria	38
		Installation	42
		Lag screw specifications	44
		Construction details	46
		Natural ageing	54
		Cleaning and maintenance	56
		Technical characteristics	57
Thermopine UTV specification	58		
Thermopine 3D specification	60		

3	Gradpanel system	Gradpanel by Thermopine Savia	66
		Pictograms guide	68
		Efficiency and sustainability	70
		Qualities and characteristics	71
		CL W Series	75
		CL W 35	76
		CL W 50 / CL W 80	78
		P W 140 Series	82
		Applications	85
		Summary of applications	86
		Face	88
		Fixed frame	90
		Sliding	92
		Sliding motorized	94
		Opening hinged	96
		Opening pivoting	98
		Awning	100
		Folding hinged	102
		Folding pivoting	104
		Lifting	106
Lifting motorized	108		
Summary of profiles	110		

1

Finsa



We are Finsa

Finsa is a company that manufactures technical wood solutions. With almost 90 years of history, it has evolved and positioned itself as one of the leading brands in the sector. Over the years, the company has become more advanced, incorporating new materials and adapting to the new times, while retaining its essence and its main values of sustainability and design.

Founded in 1931 as a small sawmill, it has been a pioneer in the manufacture of chipboard and MDF on the Iberian Peninsula, maintaining steady growth from 1931 until today. In recent years, investments have been focused on expanding our international presence and increasing our production capacity for products that have a lot of value added within the technical wood processing chain.

In this catalogue, you can see all the information about our façade products and systems, including the most detailed technical information and all the application options.



Finsa in numbers

According to the latest data for 2019.

90

Cargo ships

18

Local branches

+80

Countries

6

Logistics warehouses

95K

Lorries with real-time GPS

+7K

Containers

3.300

Employees

917

Million in sales

123

Million in investments

12

Factories

From its beginnings as a small sawmill in 1931, Finsa has gradually grown into a global company. Today, we have 18 of our own branches and, through our export department, we can reach more than 80 countries all over the world.

Our commitment to our customers does not end with the manufacture of quality products. We manage your delivery by land or sea, ensuring that it's on time and in perfect condition, thanks to a large logistical network. In addition, we are continuously investing in order to adapt to the new needs of the market.



Sustainability



Credits for environmental certifications

Finsa materials are made from wood, which is a renewable, recyclable, sustainable material. Using our products in construction projects contributes to the obtaining of credits for LEED, BREEAM or VERDE certification seals. These certify the environmental performance of products and systems and, therefore, their contribution to the environmental quality of buildings.



BREEAM®



Certifications: Wood from sustainable forests

The Chain of Custody certifies the movement of raw materials from the forest to the consumer/customer, at all stages of the process, i.e. it guarantees that the products purchased by the customer are made from materials originating from forests that are managed in a sustainable manner.



This guarantee is materialised through the PEFC™ and FSC® certificates, which have to do with the manufacture and marketing of products that are derived from wood.



Environmental Product Declaration (EPD®): Ecological footprint and transparency

The EPD® is a tool for providing clear and transparent information regarding the impact that a given product has on the environment throughout all stages of its life cycle.

In terms of our products, it confirms that wood is a material which maintains the capture of greenhouse gases throughout our production process.

1m³ chipboard
= -744kg CO₂

Calculate the carbon footprint value of your product based on the verified EPD® of our products.



Product sustainability certification

Cradle to Cradle® certification makes it possible to verify that products, from design to recycling, create a positive impact. Not only on the environment (healthy and recyclable materials, water management, use of renewable energies, etc.), but also on people and in the economy (social responsibility).



Savia is dedicated to the transformation and commercialization of solid wood, is part of Finsa and specializes in the development of solutions and new products in close collaboration with its customers.

Experience, production and logistics capacity, human resources and an innovative mindset focused on the development of new solutions in wood: these are values that we have inherited from our industrial group. With all these backgrounds, Savia was born: a company that seeks to open new paths for solid wood, with innovative proposals and developments adapted to current needs.

In addition to standard solid wood products, Savia specializes in new solutions in collaboration with other industries, firms, architects and designers. Savia's team is constantly working on new and innovative projects, with the aim of solving challenges and developing innovative applications that respond to the current and future needs of the market and the spaces we inhabit.

Savia has the capacity to face any development with the support of a highly consolidated technical and productive structure, supported at an industrial and logistical level by Finsa.

2

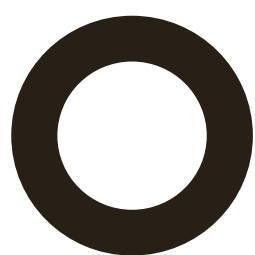

THERMO
PINE

Savia



Façades with Savia Thermopine

As part of its mission to offer wood solutions for architecture and interior design, in recent years, Finsa has developed a durable, non-toxic wood cladding solution for façades that has a low impact on the environment and is sustainable: Savia Thermopine heat-treated pine.

The dimensional stability that characterizes this material makes it ideal for façade application, allowing the designer to bring the warmth of high-performance wood to the façade of the building, and providing a skin that is natural and 100% recyclable.

UTV channel profile
ThermoPine façade.



What is Savia Thermopine?

Shou Sugi Ban is a traditional Japanese technique that is more than three centuries old. It consists of applying a thermal treatment to wood in order to improve its performance in outdoor environments. This process carbonises the outer layers of the wooden boards, creating a barrier and protecting them from degradation caused by fungi and xylophagous insects.

In line with this philosophy, at the beginning of the 20th century, the first scientific studies on the heat treatment of wood were carried out (Tiemann, 1920). While carrying out research on drying at high temperatures, a decrease was observed in the equilibrium moisture content and the swelling of the wood. Another research study carried out in Germany by Stamm and Hansen (1937) sought to observe the behaviour of heat-treated wood in atmospheres formed by different gases. This process of thermal treatment has been refined over the years to become what we know today as Thermopine;

100% natural, thermally-modified wood that takes on excellent properties for use outdoors, with a treatment that only uses water and heat.

During this process, a modification is produced in the wood's structure, resulting in the decomposition of the hemicellulose chains and the reorganization of the cell wall. This leads to an increase in durability and a reduction in the hygroscopicity of the wood, which results in a significant improvement in dimensional stability.

-
- 1 Untreated pine.
 - 2 Heat-treated pine.

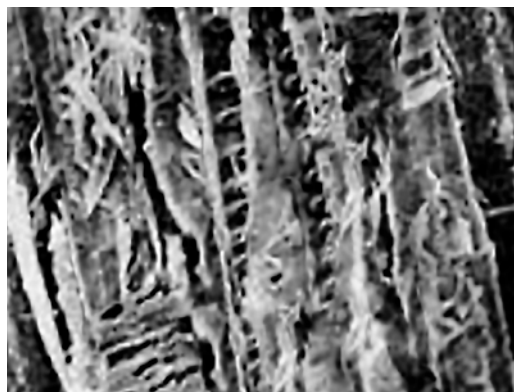

1

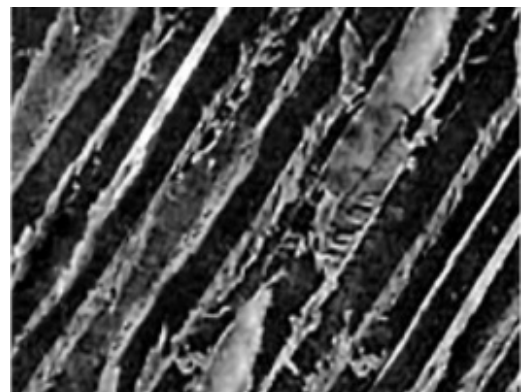

2

Heat treatment

The ThermoPine manufacturing process is very environmentally friendly, as it does not use any toxic or polluting products. In order to achieve the thermal modification of the wood, we only use temperatures between 190°C and 210°C, depending on the type of heat treatment, and water vapour, all within a vacuum atmosphere that has no oxygen.

Due to the degradation of some of the constituent molecules of the wood, such as terpenes or phenols, as a result of the effect of the temperature, a number of completely natural extracts are produced and managed effectively.

Essentially, we manufacture two categories of heat-treated wood: ThermoPine-S and ThermoPine-D. The difference between them lies in the maximum temperature reached during the heat treatment process, and therefore in their resultant properties.

Heat treatment chamber.



Categories

Thermopine-S (Stability)

Indoors

The maximum temperature reached during thermal modification for Thermopine-S is 190°C. In this way, we achieve a nice light brown colour and a considerable improvement in dimensional stability due to the decreased equilibrium moisture content of the wood. It is usually applied indoors.

Thermopine-D (Durability)

Outdoors

The maximum temperature reached during thermal modification of Thermopine-D is 210°C. With this temperature level, we achieve an elegant dark brown colour. The dimensional stability and durability qualities of the wood are significantly improved due to the decreased equilibrium moisture content and the reduction in hemicelluloses, which leads to a loss of nutrients that hinders the growth of fungi and attacks from xylophagous insects. Designed for outdoor applications.

-
- 1** Untreated pine.
 - 2** Thermopine-S.
 - 3** Thermopine-D.



1



2



3

Process stages for heat treatment

Stage 1	Heating and drying	In this stage, the wood is gradually heated using heat and steam until it reaches temperatures of between 150°C and 180°C. At the same time, high temperature drying also takes place, causing a significant decrease in the moisture content of the wood, close to 0%.
Stage 2	Heat treatment	Once the wood is prepared with the appropriate moisture content, the temperature of the chamber is increased again from 190°C to 210°C, depending on the type of heat treatment being carried out. This process uses steam and vacuum to avoid igniting the wood. The duration of this stage is approximately 4 hours.
Stage 3	Cooling and conditioning	After the heat treatment, it is necessary to reduce the temperature of the wood and condition it to the final usage conditions. Once this process is complete, the moisture content of ThermoPine is between 4.5% and 7%.

Diagram of the production process.

- a. ThermoPine-D.
- b. ThermoPine-S.

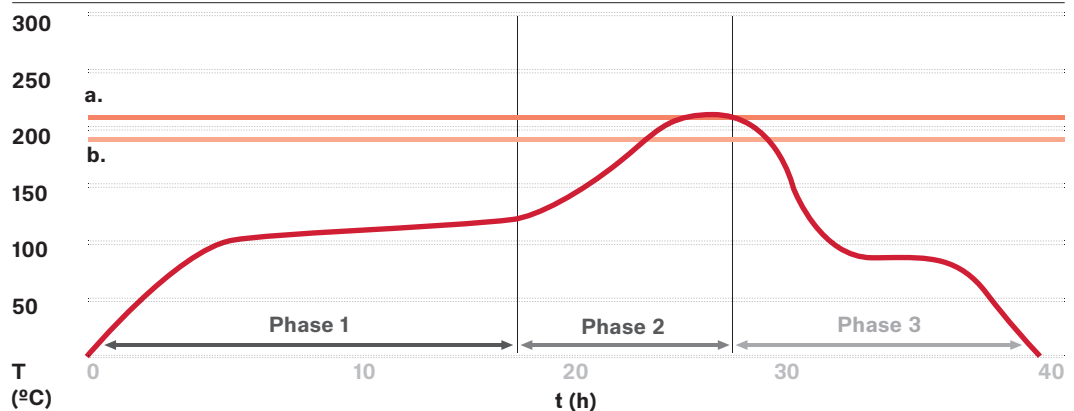

Properties



Equilibrium moisture content

The physical and chemical modifications carried out during the manufacture of Thermopine result in a 50% decrease in the equilibrium moisture content of the wood. This characteristic results in an improvement, both in terms of the dimensional stability and durability of the Thermopine.



Dimensional stability

Less moisture exchange due to lower equilibrium moisture content and reduced radial and tangential shrinkage coefficients make Thermopine a wood that has a dimensional stability that is up to 75% better than untreated wood. This allows it to perform better outdoors, minimizing movement of the parts during their service life.



Durability

The heat treatment causes a modification in the structure of the wood, producing new molecules such as furfural, which interacts with the wood's own lignin and means that the fungi enzymes do not recognise it and therefore do not degrade it. In addition, because the hemicellulose chains are destroyed, the fungi have less nutrients for their development, making Thermopine a product that is suitable for outdoor use.



Uniformity of colour

Thermopine's thermal modification treatment gives it a high degree of uniformity in terms of the colour of the wood. It takes on a dark brown colour across the whole section of the product, allowing it to be cut and planed without altering the colour. To maintain the original appearance of Thermopine, it is necessary to apply a pigmented UV protection product. Otherwise, none of the properties will be altered, but its colour will change to a nice metallic grey.



Without resin

Due to the high temperatures reached during the manufacture of Thermopine, the resin present in the wood disappears. This means that it does not exude resins during its service life, which improves the aesthetic, visual and functional quality of the Thermopine.



Without chemicals

The manufacture of Thermopine uses only heat and steam, completely dispensing with additives and chemicals. This makes the product totally natural and environmentally friendly, while maintaining an optimum level of performance.



Thermal insulation

Due to the removal of some of the constituent parts of the wood during the thermal modification process, especially the hemicellulose, Thermopine has reduced thermal conductivity. This results in a considerable improvement in thermal insulation; up to 25%.



Density

Thermopine has up to 15% less density than the wood had before the heat treatment process. This reduction is mainly due to the variation in the composition of the wood structure, caused by the effect of temperature and the reduction in the moisture content.

Self-declared carbon footprint

Wood in general, and Thermopine in particular, is a resource that comes directly from nature. It is renewable, because it can be restored by natural processes at a faster rate than human consumption, and it is recyclable, because at the end of its useful life it can be recovered for different uses, creating an authentically circular economy.

European Directive

The European Directive on the Energy Efficiency of Buildings 2010/31 requires that, in European Union member states:

- From December 31, 2018, new buildings that are occupied and owned by public authorities must be buildings whose energy consumption is almost zero.
- All new buildings must have an energy consumption of almost zero by 31 December 2020 at the very latest.

This is, therefore, a new time for architecture and construction; one that is marked by sustainability. This is already transforming the way we design, build and use buildings, as we seek to reduce greenhouse gas emissions and the impact they have on our environment.

Current status of the industry

As a sector, construction is currently responsible for 40% of all CO₂ emissions into the atmosphere. It generates 30% of the planet's solid waste and accounts for 20% of all water pollution.

Reducing the impact that the construction industry has on the environment is therefore essential.

From now on, it is not only essential to reduce the CO₂ emissions that a building emits as a result of its energy consumption during its useful life, but also the CO₂ emissions that are generated in the process of constructing the building.

Specifically, Thermopine has a carbon footprint of -714.69kg CO₂eq/m³.

Emissions and materials

The carbon footprint generated by a building is largely due to the material with which it is built, or in other words, to the amount of CO2 emissions that are emitted into the atmosphere throughout the life cycle of the materials which are used to build it; from the process of extracting the raw materials, to production, manufacture,

transport, and treatment of waste or residues.

The table below shows a comparison between the net CO2 emissions produced by different materials, including their carbon absorption capacity.

01. Aluminium	27000
02. Steel	16900
03. PVC	4500
04. Recycled steel	3800
05. Prefab concrete	350
06. Brick	150
07. Thermopine	-830

(Units in Kg CO₂eq/m³)

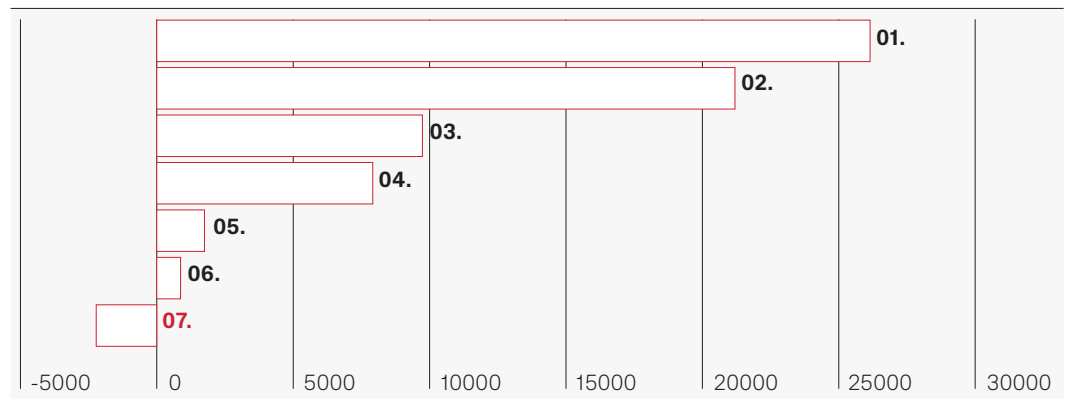

Advantages of wood

As a construction material, wood offers many environmental benefits in comparison to other construction materials, as it is the only material that achieves a negative carbon footprint at the end of its life

cycle. It offsets the CO2 emissions emitted during its production with the amount of CO2 it absorbs from the atmosphere, and which it needs for its growth, when it is a tree.

Cradle to Cradle Certification

Savia's Thermopine product is Cradle to Cradle Gold certified.



Usage classes

Wood and products derived from wood must be installed in compliance with the usage class. The UNE Standard - EN: 335:2013 specifies five usage classes, depending on the location of

the wood and the possible risk of attack by xylophagous agents, according to the degree of humidity it reaches during its service life. ThermoPine has a Usage Class of 3.2.

Graphic with the different usage classes, classified by numbers.

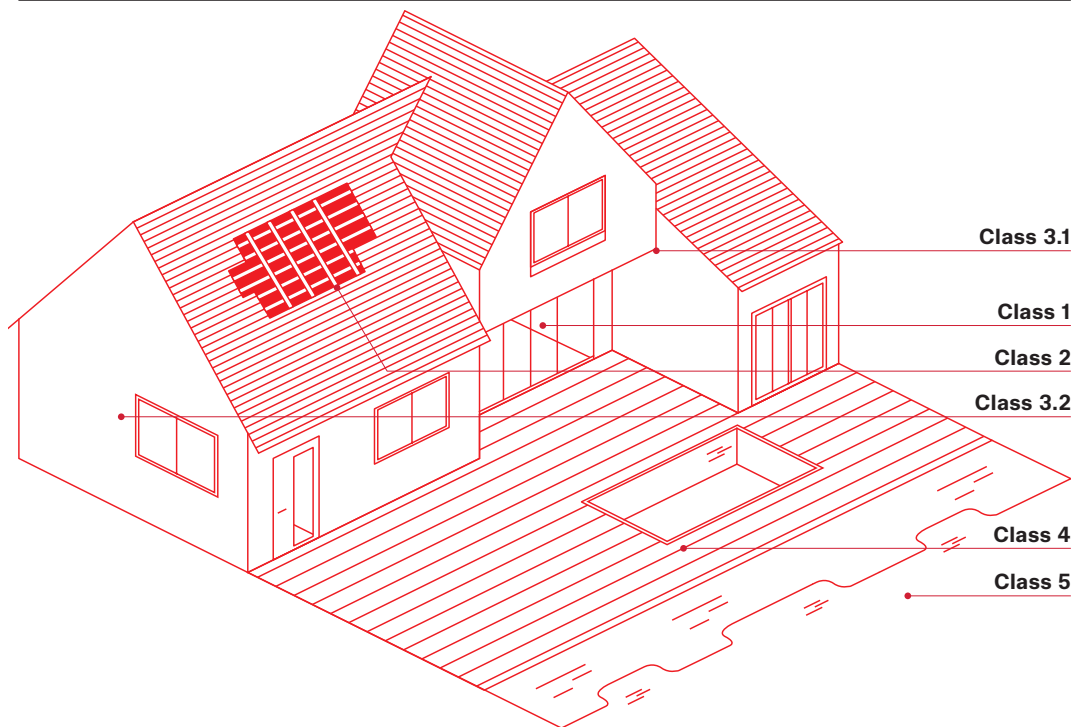

Class 1.

Wood applied indoors, under cover and without any type of humidification.

Class 2.

Wood applied indoors, under cover, but where high levels of humidity may occasionally occur.

Class 3.

Wood exposed to the elements and without contact with the ground.

3.1. Element outdoors, above the ground but protected.

3.2. Element outdoors, above the ground but not protected.

Class 4.

Wood in contact with the ground or with fresh water.

Class 5.

Wood in direct contact with salt water.

Escola Waldorf

Madrid
Medgon

**Savia Thermopine
Superpan Tech P5**
facade and structure

Photographs by
Héctor Santos-Díez



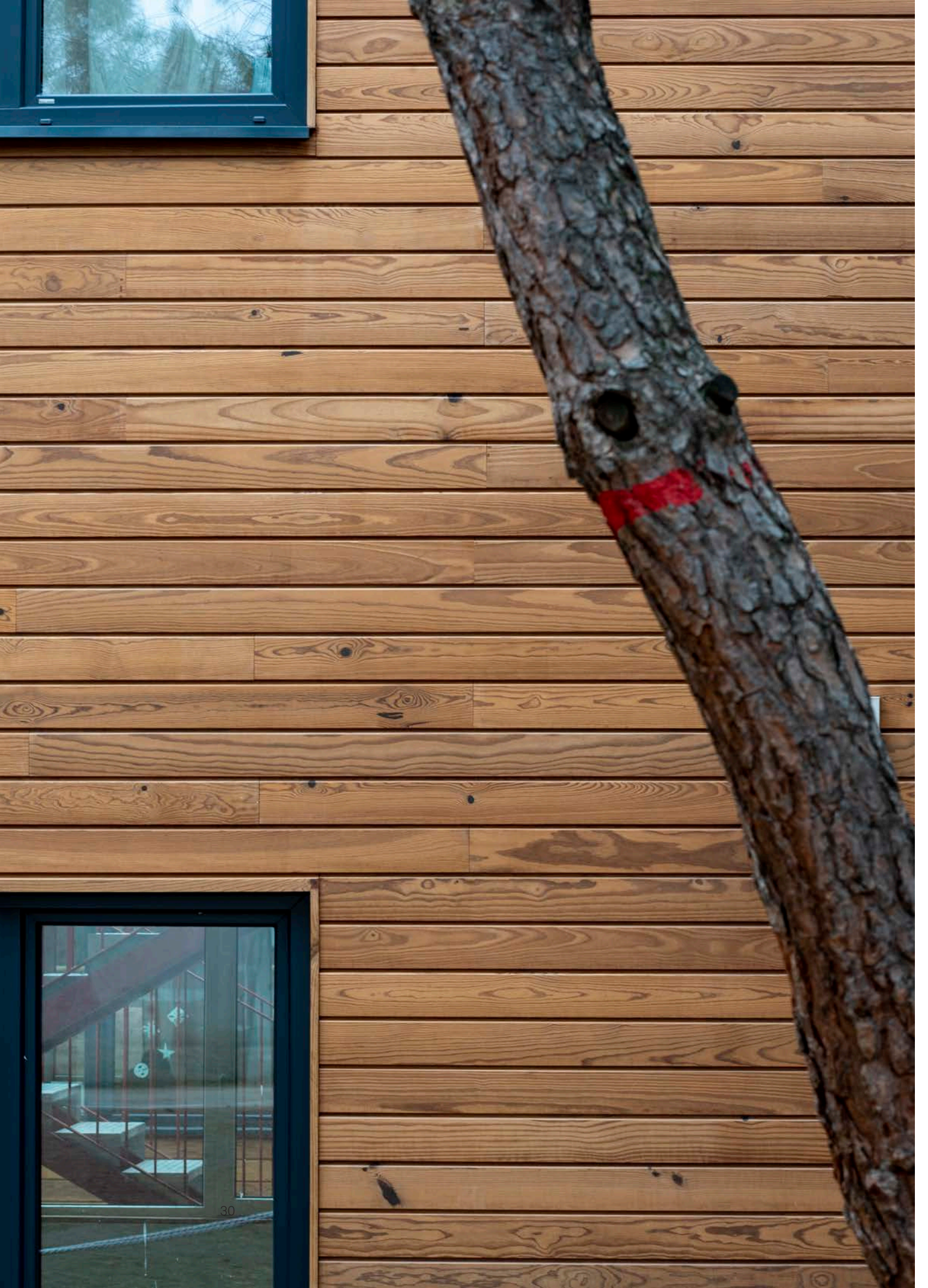

Cladding range

We have developed a range of profiles that allow the designer to create architectural coverings in different styles. From a more traditional solution like the horizontal tile layout with UYL profile, to the 3D multi-slat façade with a vertical layout that allows for movement in the façade by playing with two different thicknesses.

The Combi smooth is a novelty that stands out, allowing for vertical and horizontal layouts, while offering a notable increase in the ventilation of the chamber depending on the separation of the profiles. This cannot be seen from the front, thanks to the inclined machining of the heads.

Lastly, we include the corner profile, making it possible to protect the heads where the plane of the façade changes.

Standard façade profiles

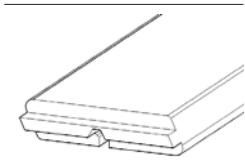

Smooth pine Combi

Dimensions (mm)	2400x85x20
Profiles Pack of 5 units	1,02m ²
Layout	Vertical/Horizontal
Quality	Premium



85x20 mm

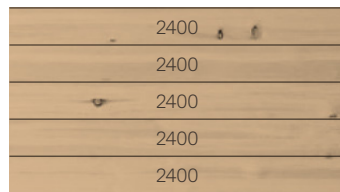

UTV channel profile pine façades

Dimensions (mm)	2400x140x20
Profiles Pack of 4 units	1,35m ²
Layout	Vertical/Horizontal
Quality	Premium



140x20 mm

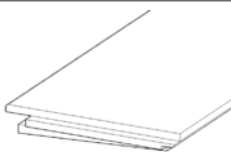
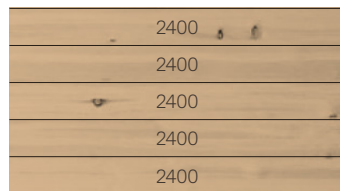

UYL channel tile pine façades

Dimensions (mm)	2400x120x20
Profiles Pack of 4 units	1,15m ²
Layout	Vertical/Horizontal
Quality	Premium



120x20 mm

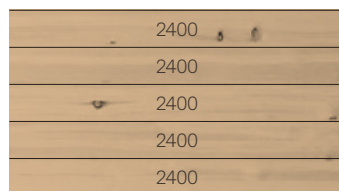

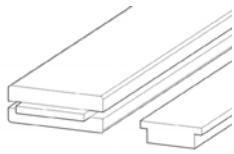

Multi-slat smooth 3D façade

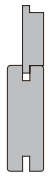

70x26/45x15 cm

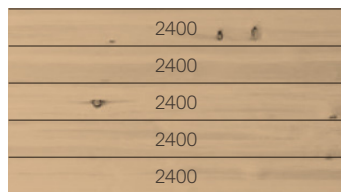

Dimensions (mm)	2400x70x26 2400x45x15
------------------------	--------------------------

Profiles Pack of 6 units	0,83m ²
---------------------------------	--------------------

Layout	Vertical
---------------	----------

Quality	Premium
----------------	---------

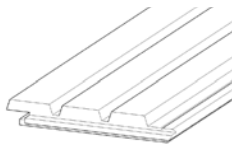

Triple façade Scotch pine



140x20 cm



Dimensions (mm)	2400x140x20
------------------------	-------------

Profiles Pack of 4 units	1,35m ²
---------------------------------	--------------------

Quality	Standard
----------------	----------

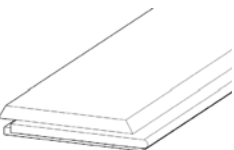

PDL façade pine

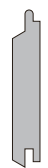

120x20 cm

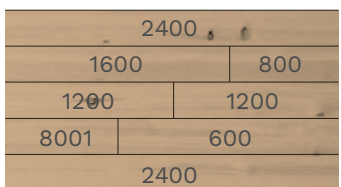

Dimensions (mm)	2400x120x20
------------------------	-------------

Profiles Pack of 6 units	1,73m ²
---------------------------------	--------------------

Layout	Vertical/Horizontal
---------------	---------------------

Quality	Premium
----------------	---------

Standard façade profiles

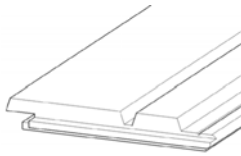

Façade pine double



140x20 cm

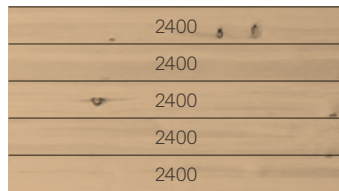

Dimensions (mm)	2400x140x20
Profiles Pack of 4 units	1,35m ²
Layout	Vertical/Horizontal
Quality	Premium

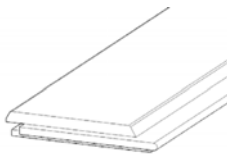

STV façade
Scotch pine



140x20 cm

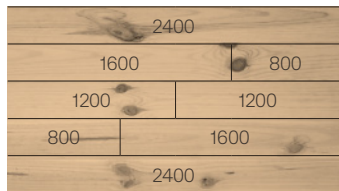

Dimensions (mm)	2400x140x20
Profiles Pack of 6 units	2,02m ²
Layout	Vertical/Horizontal
Quality	Standard

Installation accessories

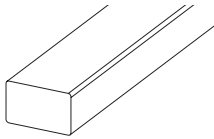

Red pine slats
in autoclave

Profiles 2400x30x30 mm
Pack of 9 units

Profiles 2400x60x38 mm
Pack of 4 units

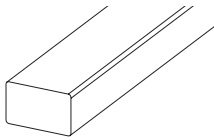

Brushed pine slat

Profiles 2400x40x26 mm
Pack of 6 units

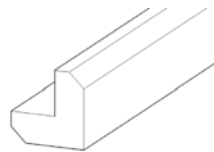

THT pine corner profile

Profiles 2000x50x50 mm
Pack of 6 units

Sections and finishes

We adapt to the needs of the architect, helping to define the most suitable sections for each project.

Solutions on request

Custom-made profiles. Maximum section of 150x45 mm. Lengths up to 4,500 mm with finger joint. Option to heat treat other species on request. Thermopine Pigmentation.

Pigmentation

Thermopine is dark brown in colour and it can be stained, thanks to the solid pigments provided by the protective varnish, with the teak colour being the one that is most similar.

Thermopine pigmentation.

- 1**
Oak stain
- 2**
Teak stain
- 3**
Wenge stain
- 4**
Gray stain



1



2



3



4

Building in Xeneral Pardiñas

Santiago de Compostela
MRM Arquitectos

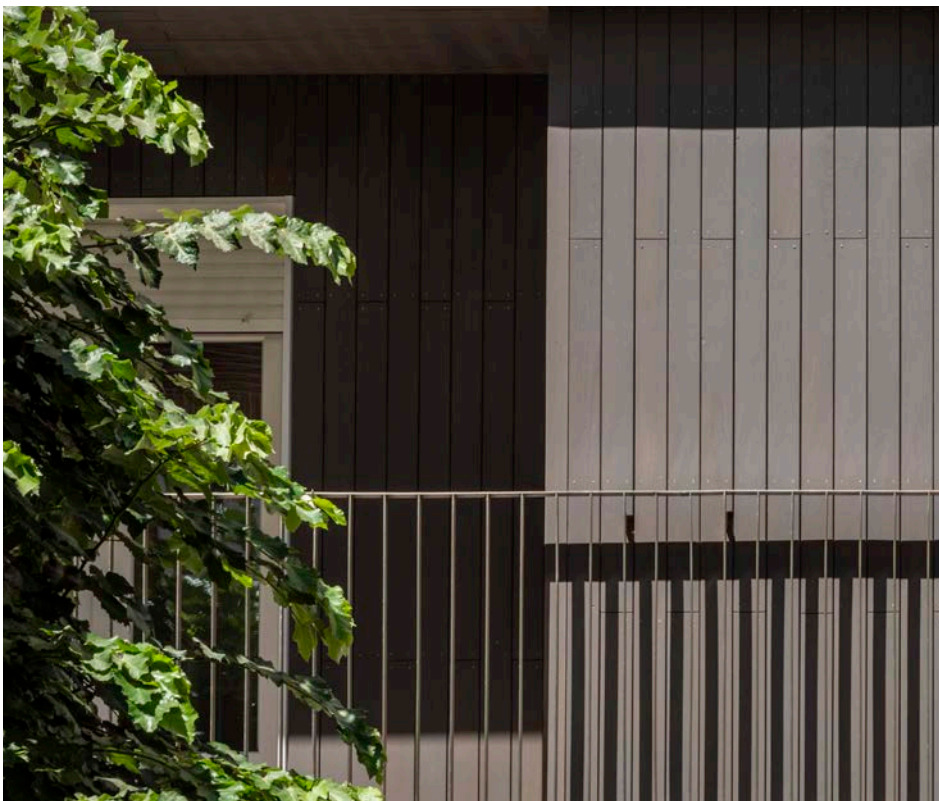
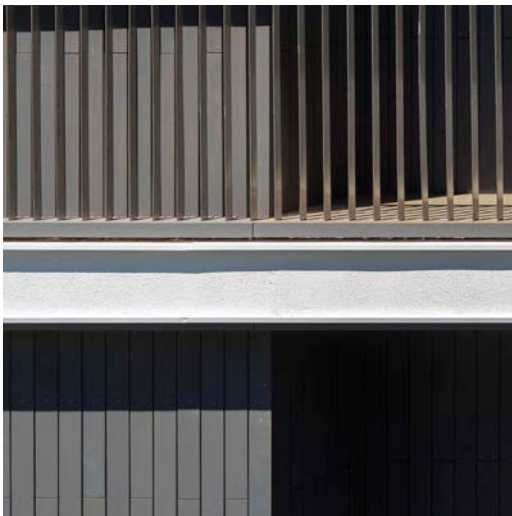
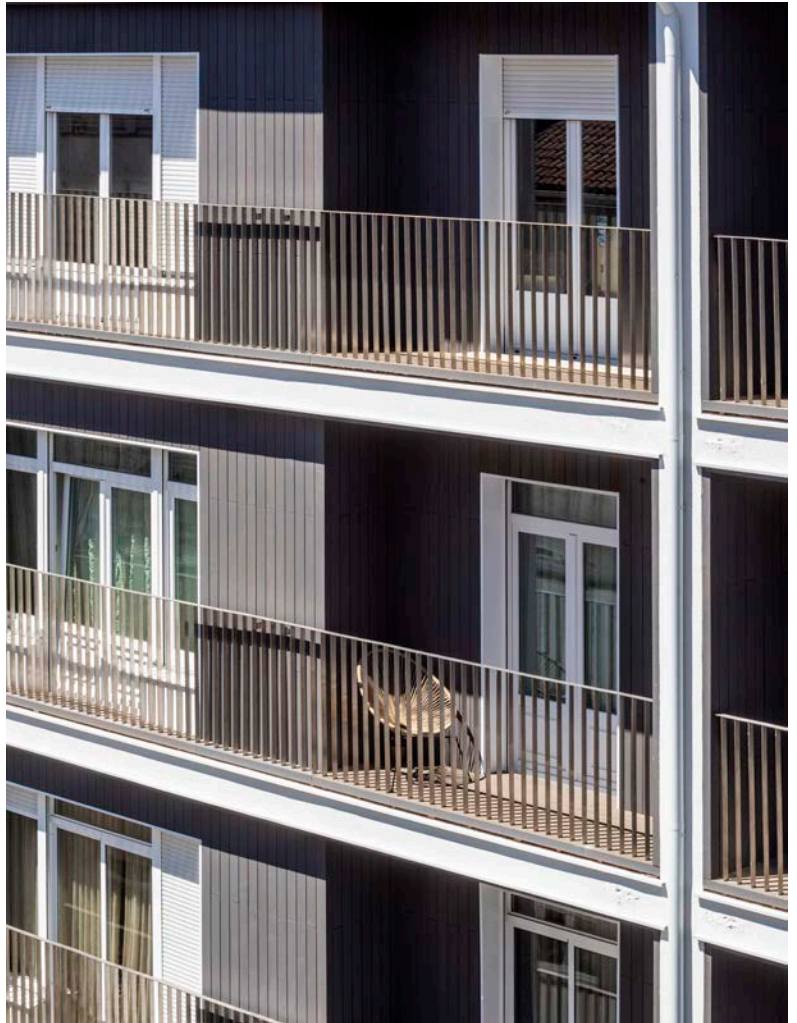

Thermopine Savia
façade cladding

Photographs by
Héctor Santos-Díez



Quality criteria of Savia Thermopine

		Premium quality	Standard quality
Sawing marks		×	×
Bark		×	×
Tap		×	×
Cracks		×	×
Heartwood		×	✓ Less than 20 cm on the visible side, without limit on non-visible side.
Traces of resin		✓ Up to 4 resin marks, less than 6 x 1 cm or 3 x 2 cm.	✓ Up to 4 resin marks, less than 6 x 1 cm or 3 x 2 cm.
Knots		✓ Up to 4 node groups 5 cm in diameter at most.	✓ sem limite, incluindo fendas de nós

		Premium quality	Standard quality
Holes		✗	✓ In machining if they do not affect functionality. No pass-through with a diameter less than 10 mm.
Rot		✗	✗
Fungi		✗	✗
Warping		✓ Less than 30 mm	✓ Less than 30 mm
Curvature of the edges		✓ Less than 20 mm	✓ Less than 20 mm
Curvature of faces		✓ Less than 20 mm	✓ Less than 20 mm

* Slight defects on the far side are permissible as long as they do not affect functionality.

** We guarantee the quality of Thermopine in 90% of the volume supplied.

*** Due to the heat treatment process performed to make the Thermopine, the knots may have small cracks which can be repaired with putty.

**Relaxation area
in pharmaceutical
sector offices**

Alcobendas
Madrid
3G OFFICE

Savia Thermopine

Cladding facades



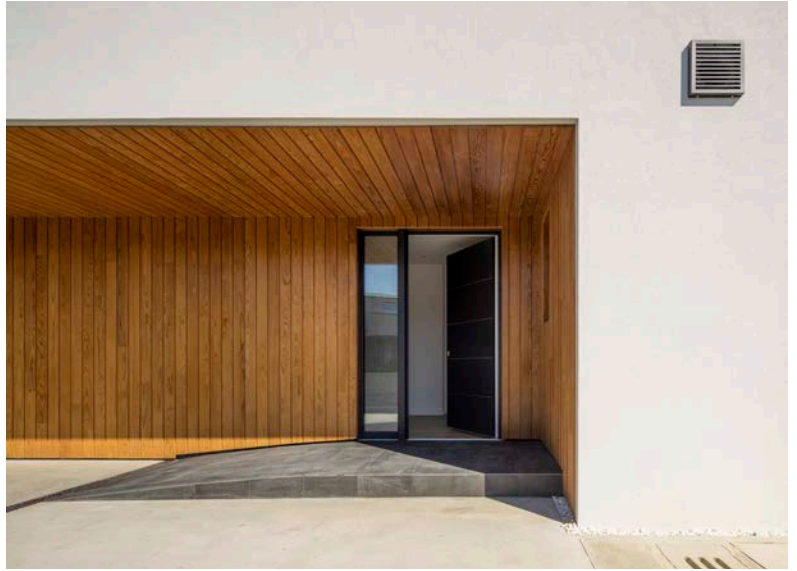

Casa passivhaus M&C

Santiago de Compostela
María Sánchez Ontín (The Cambium Design)

Savia Thermopine (Perfil UTV)

Cladding facades



Installation

In order to ensure optimum performance of ThermoPine façade profiles, there are some installation recommendations that should be taken into account.

Batten

The batten is fixed to the supporting wall, allowing the ThermoPine cladding to be separated from it. This creates a ventilated chamber that optimizes the performance and durability of ThermoPine when used outdoors. This chamber must be at least 30mm wide and it must allow air to enter and exit through the chamber at the bottom

and the top ends respectively.

The batten must be fastened to the supporting wall with a fastening element that is suitable for the wall in question. These fastening elements must be at least 100 mm in length with a maximum separation of 500 mm.

Lag screw

The façade profiles must be fastened to the battens with lag screws that are specifically for wood. To prevent rusted lag screws from staining the ThermoPine, we recommend the use of stainless steel lag screws that are of A2 quality at a minimum.

Due to the fact that the heat treatment process makes ThermoPine more brittle, we recommend the use of

self-tapping lag screws. However, pre-drilling may be necessary in order to prevent the profiles from cracking. The diameter of the pre-drilling shall be equal to the inside diameter of the lag screw.

We recommend the use of lag screws with fastening thread, with a minimum diameter of 4.5mm.



SCREWS WITH THREAD
FIXATION



CLIP TYPE
CLAMP

Lag screw specifications

Lag screw minimum length and position, depending on the ThermoPine façade profile.

For each profile a view of a horizontal section of the façade is shown.

Combi Clip

Grapa tipo Clip

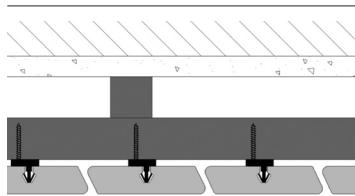

PDL

Lag screw
4,5 x 45mm

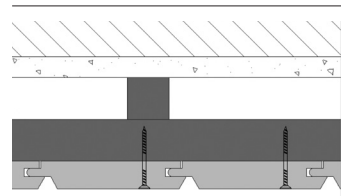

Canal UTV

Lag screw
4,5 x 45mm

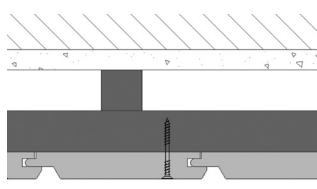

Tile UYL

Lag screw
4,5 x 45mm

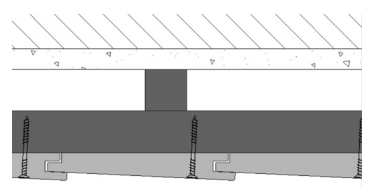

Façades 3D

Lag screw
4,5 x 50mm

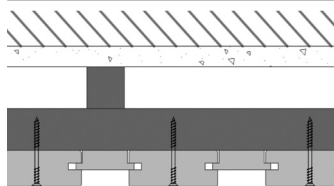

Duplo

Lag screw
4,5 x 45mm

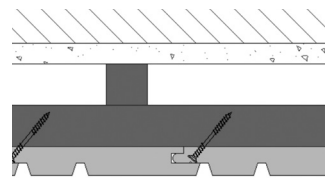

STV

Lag screw
4,5 x 45mm

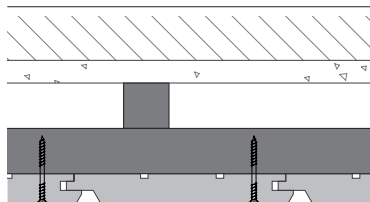

Triplo

Lag screw
4,5 x 45mm

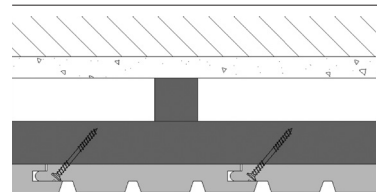

Service center
A Ramallosa. Galuresa
Teo, A Coruña
MRM Arquitectos

Savia Thermopine
stained black
Exterior panneling
inside and outside

Photographs by
Héctor Santos-Díez

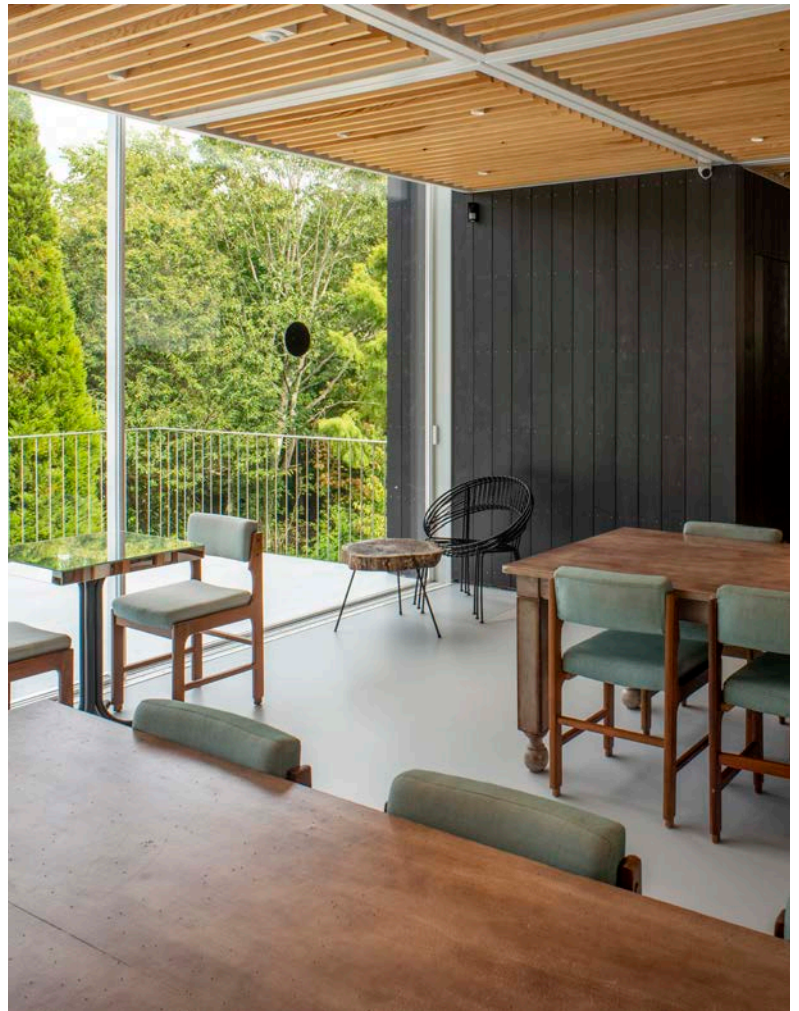

Construction details

Horizontal layout

Façades

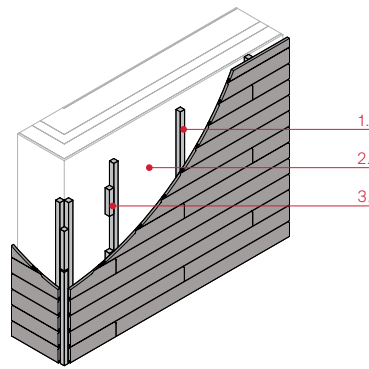
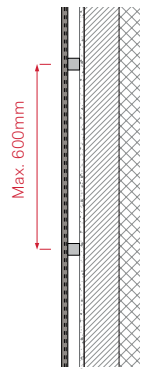

Each profile must be supported by at least two battens. If necessary, an express nail can be fastened to the main batten that is 100mm longer than the width of the façade profile.

1. Batten with autoclave treatment of 30x30mm.
2. Water-repellent mortar.
3. Express nail with autoclave treatment of 30x30mm.

Window

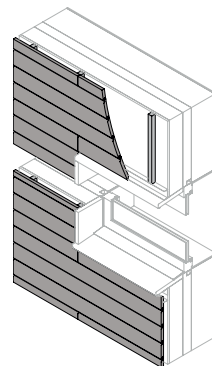

Where the façade profiles meet parts of the window, it is important to respect the clearances and separations indicated, in order to allow both the movement of the wood and the passage of air through the chamber that is created behind the profiles.

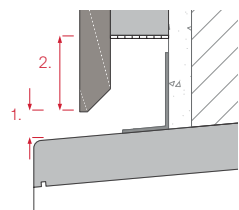

Detailed views of corner B.
 1. 20mm.
 2. 50mm.

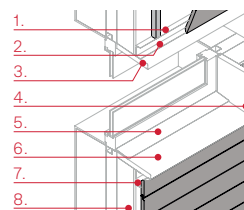

1. Insect mesh.
2. 15x15mm bevel.
3. Thermopine lintel.
4. Thermopine jamb.
5. Drip flashing.
6. Thermopine sill.
7. 15x15mm bevel.
8. Insect mesh.

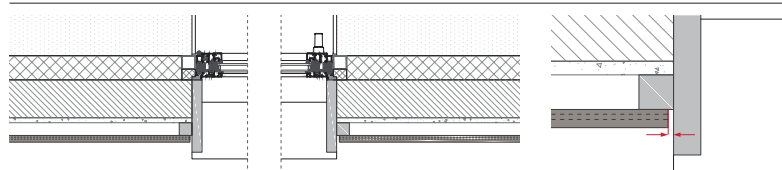

Detailed view of the window.
 Distance = 5mm.

Corner A

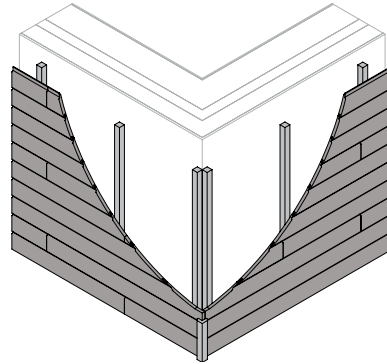
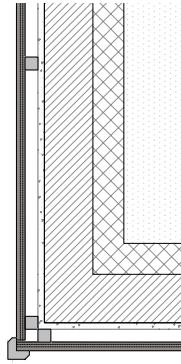

Corner solution with Thermopine corner profile overlapping and fastened to the façade profiles.

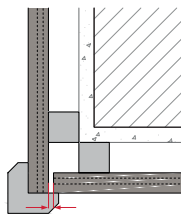

Detailed views from angle A.
Distance = 5mm.

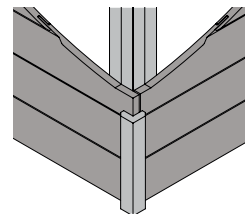

Savia Thermopine corner 50x50mm.

Corner B

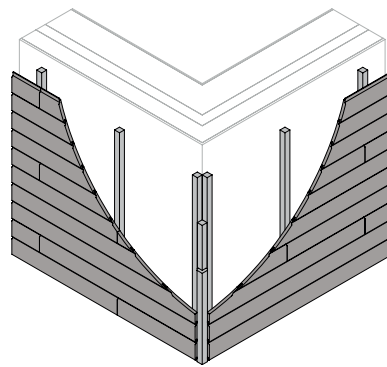
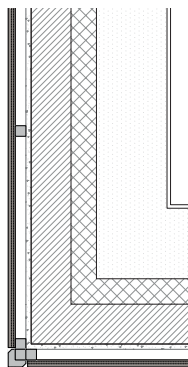

Corner solution with Thermopine corner profile sitting flush with the façade profiles and fastened to a support batten.

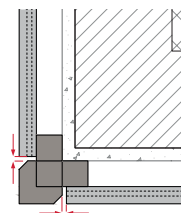

Detailed views of corner B.
Distances = 5mm.

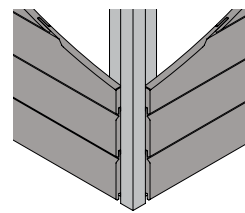

Savia Thermopine Corner 50x50mm.

Construction details

Inside corner

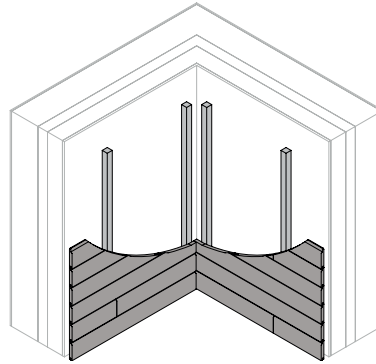
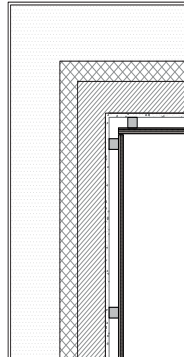

Inside corner solution maintaining clearance between the profiles to allow the wood to move.

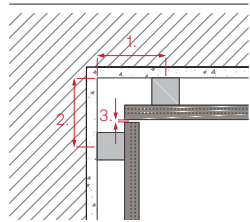

Detailed views of the inside corner.

1. 95mm.
2. 95mm.
3. 5mm.

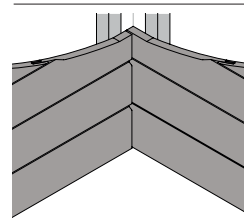

Detailed view of the inside corner.

Base

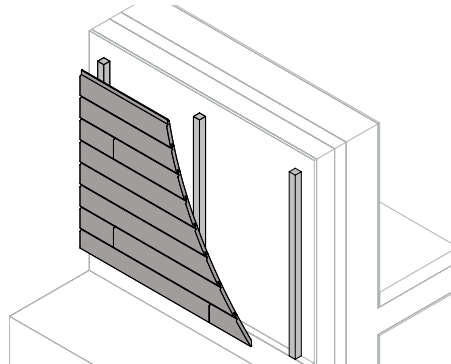
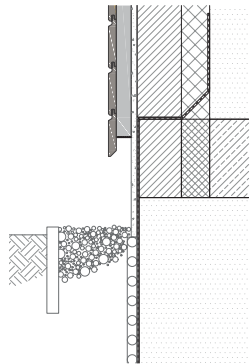

The façade profile must be at least 200 mm from the ground in order to prevent moisture and/or possible splashes to the wood, while also allowing air to enter through the lower part of the profiles.

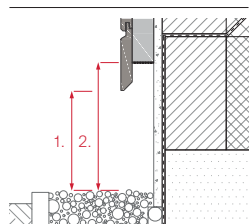

Detailed views of the base.

1. 200mm.
2. 250mm.

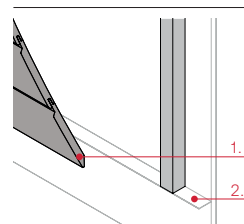

Insect mesh blocks the entry of small rodents and insects, preventing them from breeding and nesting in the air chamber.

1. 15x15mm bevel.
2. Insect mesh.

Cornice

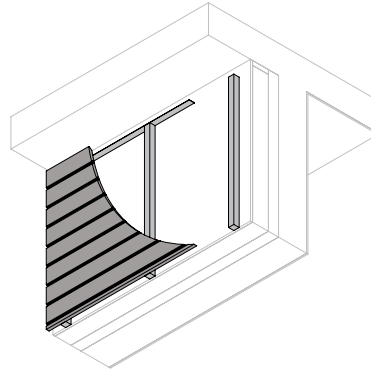
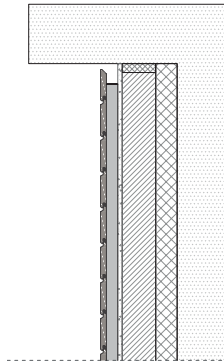

The façade profiles should remain separated from the cornice to allow air to exit and thus allow air to circulate around behind the façade.

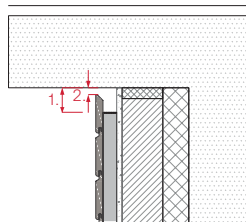

Detailed views of the inside corner.

1. 70mm.
2. 20mm.

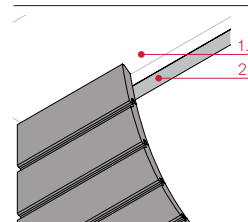

Detailed views of the inside corner.

1. 15x15mm bevel.
2. Insect mesh.

Parapet

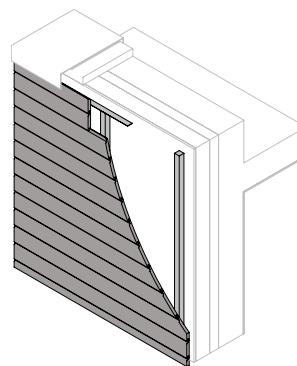
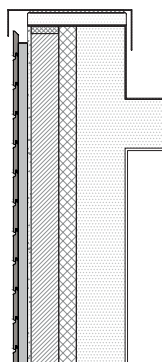

The solution for the covering parapet must allow the air circulating around behind the façade to exit, and also prevent water from entering.

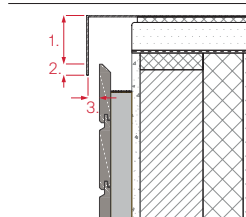

Detailed view of the parapet.

1. Min. 50mm.
2. 20mm.
3. 20mm.

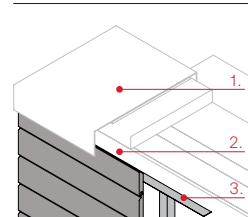

1. Metal sheet.
2. 15x15mm bevel.
3. Insect mesh.

Construction details

Vertical layout

Façade

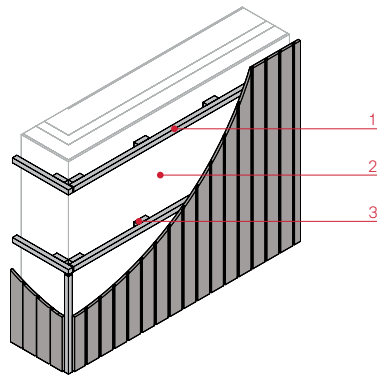
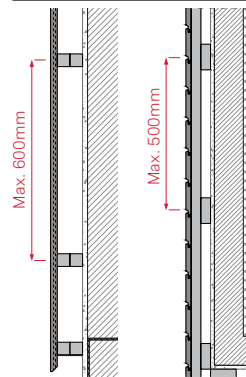

To allow for proper ventilation behind the profiles, separating express nails should be placed behind the battens. They can be fastened, together with the batten, using a centred lag bolt.

1. Batten with autoclave treatment of 30x30mm.
2. Water-repellent mortar.
3. Express nail with autoclave treatment of 30x30mm.

Window

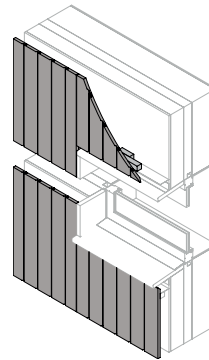

When the facade profiles reach the parts of the window, it is important to respect the clearances and distances indicated to allow the movement of the wood and the passage of air behind the profiles.

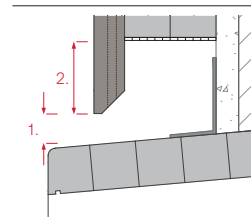

Detailed views of corner B.

1. 20mm.
2. 50mm.

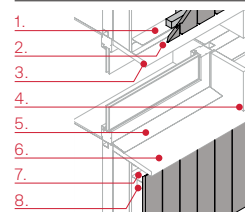

1. Insect mesh.
2. 15x15mm bevel.
3. Thermopine lintel.
4. Thermopine jamb.
5. Drip flashing.
6. Thermopine sill.
7. Insect mesh.
8. 15x15mm bevel.

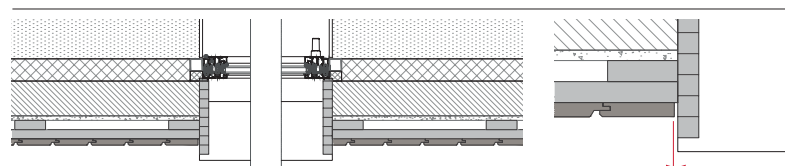

Detailed view of the window.
Distance = 5mm.

Corner A

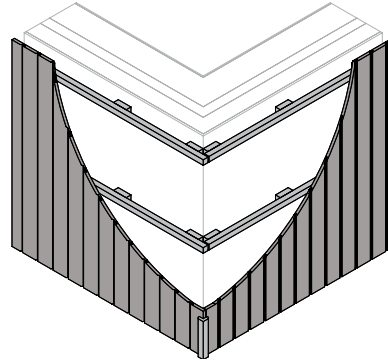
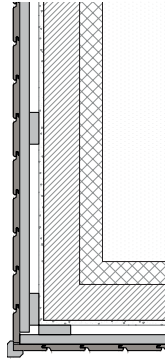

Corner system with Thermopine corner profile superimposed and fixed to the front profiles.

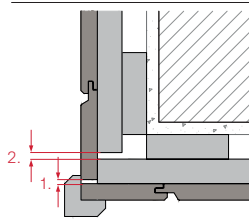

Detailed views of corner A.
1. 5mm.
2. 8mm.

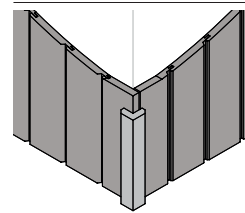

Savia Thermopine Corner 50x50mm.

Corner B

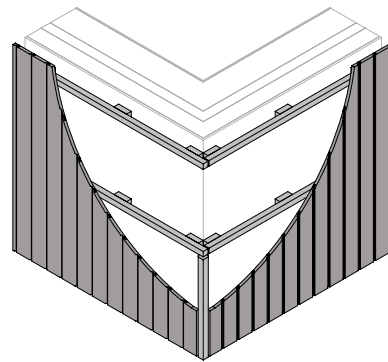
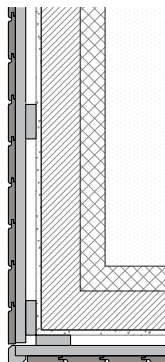

Corner solution with ThermoPine corner profile sitting flush with the facade profiles and fastened to the horizontal battens.

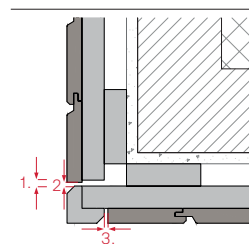

Detailed views of corner B.
1. 8mm.
2. 5mm.
3. 5mm.

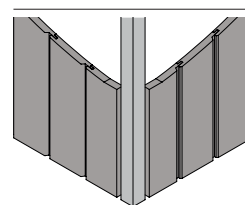

Savia Thermopine Corner 50x50mm.

Construction details

Inside corner

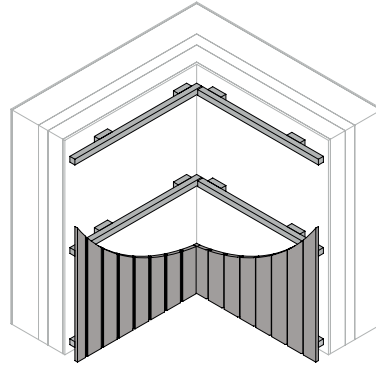
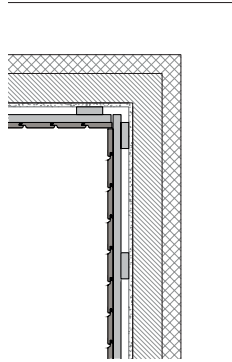

Inside corner solution maintaining clearance between the profiles to allow the wood to move.

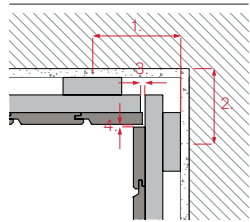

Detailed views of the inside corner.

1. 150mm.
2. 110mm.
3. 8mm.
4. 5mm.

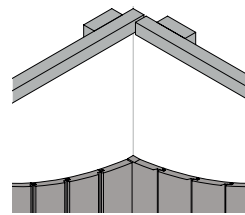

Detailed views of the inside corner.

Base

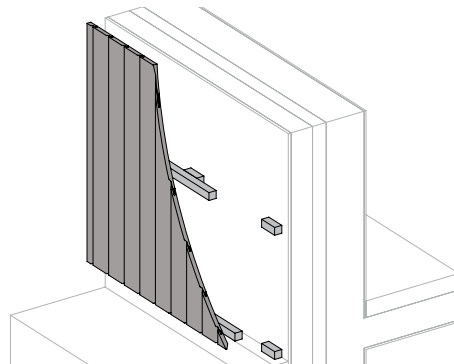
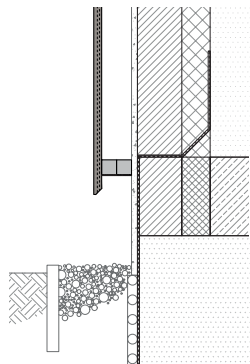

The façade profile must be at least 200mm from the ground in order to prevent moisture and/or possible splashes to the wood, while also allowing air to enter through the lower part of the profiles.

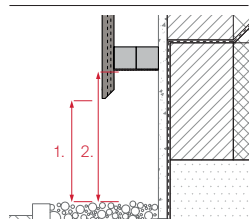

Detailed view of the base.

1. 200mm.
2. 250mm.

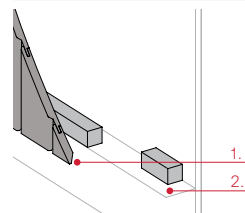

Insect mesh blocks the entry of small rodents and insects, preventing them from breeding and nesting in the air chamber.

1. 15x15mm bevel.
2. Insect mesh.

Cornice

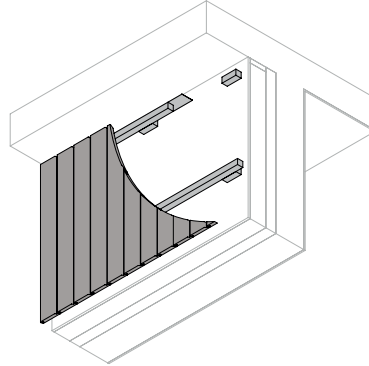
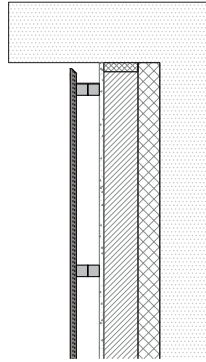

The façade profiles should remain separated from the cornice to allow air to exit and thus allow air to circulate around behind the façade.

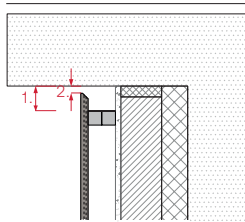

Detailed views of the inside corner.

1. 70mm.
2. 20mm.

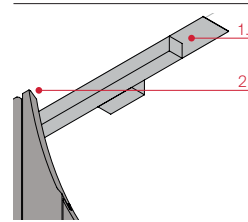

Detailed views of the inside corner.

1. 15x15mm bevel.
2. Insect mesh.

Parapet

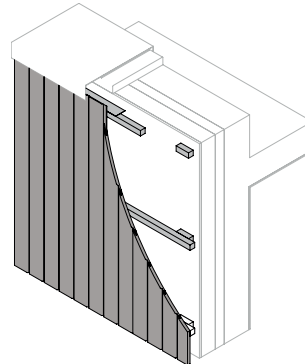
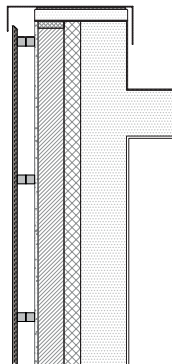

The solution for the covering parapet must allow the air circulating around behind the façade to exit, while also preventing water from entering.

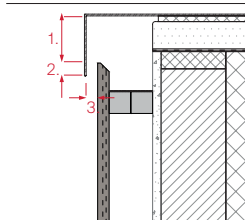

Detailed view of the parapet.

1. Min. 50mm.
2. 20mm.
3. 20mm.

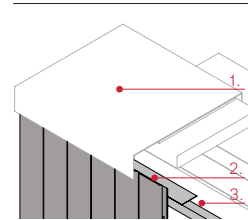

1. Metal sheet.
2. 15x15mm bevel.
3. Insect mesh.

Natural ageing

ThermoPine is a 100% natural product. If no protective product is applied or if the maintenance tasks are not carried out properly, its colour gradually evolves towards a metallic grey tone, due to the ultraviolet radiation produced by the sun.

This colour evolution is known as photo-degradation and it occurs in all types of wood (both natural and modified) and even in other types of materials.

Simulating the result of ageing.

The colour can be preserved by treating the wood once a year with a UV protector.

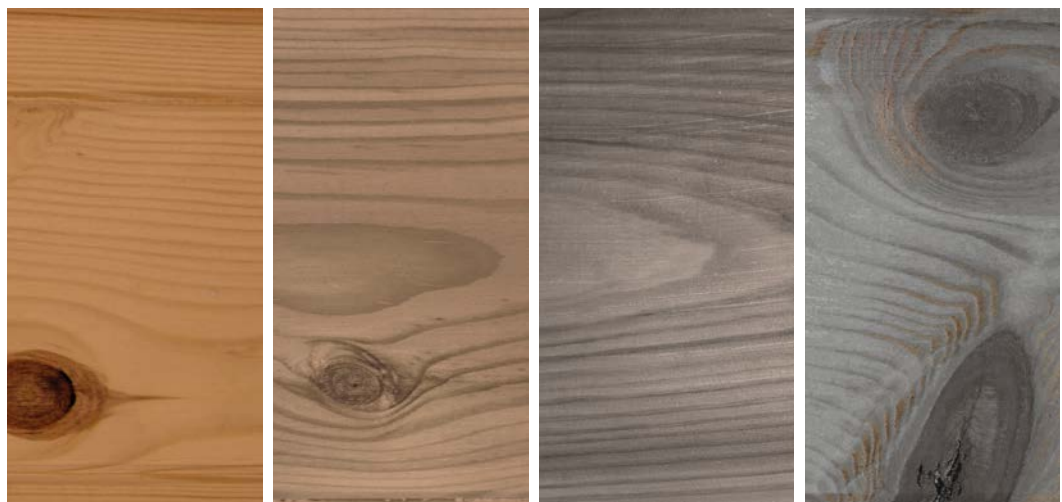

1
Dark brown
The natural result of our modification process.

2

3

4
Metallic grey
Over time, untreated products age to a beautiful silver tone.

The ThermoPine surface turns grey as a result of the effect of photo-degradation, which should not be confused with rotting of the material.

It causes the aesthetic modification of the product, as well as wear on the surface layer (approx. 1 mm). The customer can decide whether or not they like the way that ThermoPine ages, with the option of reverting to the original colour by carrying out maintenance and thus slowing down the wear.

If this ageing occurs, none of the properties of ThermoPine are altered. The change in the product's colour can be reversed at any time by applying Sikkens Cetol WF 771 in Teak Colour 085 (a colour that is similar to that which is acquired by the

ThermoPine during its manufacture).

To maintain the ThermoPine as it was originally, it should be protected with Sikkens Cetol WF 771 in Teak Colour 085 and appropriate maintenance should be carried out. The frequency of maintenance should be adjusted according to geographical location, exposure, adjustment, etc.

Due to seasonal differences in humidity between the inside and outside of the ThermoPine, small cracks may appear on the surface of the product. This is completely normal behaviour for a natural product such as ThermoPine and it does not impair any of its physicochemical properties.

Durability

When correctly installed and maintained, ThermoPine will last for more than 25 years.

See conditions on the product warranty sheet.

Cleaning and maintenance

In this section, technical considerations are established that are applicable for cleaning and maintaining the Thermopine protection and finishing product, Cetol WF 771 Colour.

Protection of ThermoPine

Thermopine is a product that is manufactured using a heat treatment process that improves the wood's dimensional stability and external durability properties, among other things. To protect it from the weather, and especially from solar

radiation, a non-filmogenic saturation system is applied. This consists of a base coat of Cetol WF 771 Saturator with a minimum of 60 gr/m² when wet and a second coat of the same product with a minimum of 40 gr/m² post-saturation.

Cleaning

It is advisable, as for all outdoor wood solutions, to clean the wooden elements of the covering, both upon completion of construction and afterwards. The purpose of cleaning is to prevent the accumulation of materials (saltpetre, bird droppings or other contaminants) that could chemically degrade the coating system.

For cleaning, use a neutral pH soap solution and rub gently with a sponge until all dirt is removed.

Cleaning can be carried out with nozzle systems, using a rotating brush to avoid accelerated wear of the finishing product.

During maintenance operations, special attention must be paid to elements located less than 25cm from the ground, or that are

in direct contact with other materials, and any possible damage that may have been caused by the passage of people (vandalism, damage due to rubbing, knocks, etc.).

Maintenance

If the plan proposed below is implemented, there will be no damage to the finishing product during the maintenance cycle. Normal small cracks may be visible in a natural product such as Thermopine due to temporary differences in humidity.

The indicated frequencies are related to the preservation of the protection of the finished product. They may need to be adjusted for aesthetic reasons due to the Thermopine turning lighter and/or grey as a result of the photo-degrading action of the sun.

The procedure for renewing the protective product consists of cleaning the surface as described above and then applying 1 coat of "Cetol WF 771 Colour" product with a brush (approx. 60 ml/m²). This product, in Teak 085 colour, is used as a protective finishing layer for ThermoPine. It will dry in the air for a minimum of 8 hours.

Maintenance recommendations.

	After installation	Normal weather	Extreme weather (coast - mountain)
First year			
Second year			
Third year			Check surface
Fourth year		Check surface	

Technical characteristics

On the following technical data sheet, the characteristics of the Thermopine product are shown.

Characteristic	Value	Standard
Density	530 +/- 50 Kg/m ³	UNE-EN 408:2011+A1:2012; UNE-56-531
Humidity	4,5-7 %	UNE-EN 408:2011+A1:2012; UNE-EN 13183-1:2002
Tangential shrinkage coefficient	4,65%	UNE-EN 56533:1977
Radial shrinkage coefficient	1,91%	UNE-EN 56533:1977
Modulus of elasticity at medium bending	10752 N/mm ²	UNE-EN 408:2011+A1:2012
Resistance at medium bending	49 N/mm ²	UNE-EN 408:2011+A1:2012
Impact resistance (Charpy)	31,74 KJ/m ²	UNE-EN ISO 179-1:2011; UNE-CEN/TS 15679:2009
Indentation resistance (Brinell)	2,11 Kp/mm ²	UNE-EN 1534:2011
Thermal conductivity (λ) in (W/m.k)	0,10-0,13	UNE-EN 14915:2013+A1:2017
Durability xylophagous fungi	2-durable	UNE-EN 350 2017
Durability xylophagous beetles	D-durable	UNE-EN 350 2017
Usage Class	3.2	UNE-EN 335 2013
Fire performance	Class D-s2, d0	UNE-EN 14915: 2013+A1:2017

Thermopine UTV Specification

External ventilated façade cladding, with slats made of solid, heat-treated pine wood. Savia's ThermoPine, treated by exposing the wood to temperature cycles of up to 220°C and water vapour, in an oxygen-free, pressure-controlled atmosphere, rectangular section, with UTV tongue and groove edge, 2400x120x20mm and usage class 3.2, in accordance with UNE-EN 335.

Subsequent Sikkens Cetol WF 771 surface treatment for horizontal wooden profiles, choice of colour, as a protective and decorative treatment; horizontal positioning with screws, on a vertical support substructure, consisting of 30x30mm section battens, made of Finsa red pine wood, with autoclave treatment for usage class 4, with a separation of 600mm, positioned on self-adhesive butyl rubber tape.

Including anti-rodent grid to protect the ventilated chamber and self-tapping screws for fastening the supporting substructure. The price does not include thermal insulation.

Item breakdown

	Units	Description	Yield	P. unit.	Amount
1		Materials			
	m	Self-adhesive butyl rubber tape, 1 mm thick and 50 mm wide, working temperature range from -30 to 80°C, for indoor and outdoor use, for sealing holes formed when nailing wooden elements, supplied in rolls that are 15 m in length.	1,7	2,05	3,49
	m	Vertical batten made of treated Savia red pine wood, class 4, in accordance with UNE-EN 335, 2400x30x30mm, centre-to-centre distance 600mm.	2,7	1,36	3,67
	Unit	Spax screw for fastening batten to structure 6x100mm.	9	0,80	7,20
	m ²	Savia Thermopine UTV wooden slats 2400x120x20mm.	1,05	38,90	40,85
	Unit	Spax screw for external fastening of wooden profiles to battens 4.5x45mm A2 quality with fastening thread.	28	0,22	6,16
	m	Anti-rodent grid made of perforated galvanized steel 'L' shaped profile , 30x20mm, for the protection of ventilation chambers in walls with wooden structures.	0,2	3,20	0,64
	m ²	Sikkens Cetol WF 771 surface treatment system for horizontal wooden profiles, in three layers. 60ml/m ² /layer.	1	4,12	4,12
					Subtotal materials 66,12
2		Labour			
	h	Senior installer	0,906	19,42	17,59
	h	Assistant installer	0,906	17,90	16,22
	h	Senior painter	0,138	18,89	2,61
	h	Assistant painter	0,069	17,90	1,24
					Subtotal of labour 37,65
3		Additional direct costs			
	%	Additional direct costs	2	103,78	2,08
					Direct costs (1+2+3) 105,85

Thermopine 3D Specification

External ventilated façade cladding, made of Savia's Thermopine heat-treated solid pine wood slats, treated by exposing the wood to temperature cycles of up to 220°C and water vapour, in an oxygen-free, pressure-controlled atmosphere, rectangular section, smooth multi-slat, of 2400x70x26 and 2400x45x15mm, with usage class 3.2, in accordance with UNE-EN 335.

Subsequent Sikkens Cetol WF 771 surface treatment for vertical wooden profiles, choice of colour, as a protective and decorative treatment; vertical positioning with screws, on a horizontal support substructure, consisting of 30x30mm section battens and express nails made of Finsa red pine wood, with autoclave treatment for usage class 4, with a separation of 600mm between battens and 500mm between nails, positioned on self-adhesive butyl tape.

Including anti-rodent grid to protect the ventilated chamber and self-tapping screws for fastening the supporting substructure.

The price does not include thermal insulation.

Item breakdown

	Units	Description	Yield	P. unit.	Amount
1		Materials			
	m	Self-adhesive butyl rubber tape, 1 mm thick and 50 mm wide, working temperature range from -30 to 80°C, for indoor and outdoor use, for sealing holes formed when nailing wooden elements, supplied in rolls that are 15 m in length.	1,7	2,05	3,49
	m	Savia's treated red pine wooden vertical batten class 4 in accordance with UNE-EN 335, 2400x30x30mm, 600mm centre-to-centre distance on 30x30x100mm express nail every 500mm.	3,3	1,36	4,49
	Unit	Spax screw for fastening batten to structure 6x130mm.	9	0,90	8,10
	m ²	Finsa ThermoPine smooth wooden multi-slat 2400x70x26 and 2400x45x15mm.	1,05	40,90	42,95
	Unit battens	Screw for external fastening of wooden profiles to Spax 4.5x50 mm A2 quality with fastening thread.	32	0,22	7,04
	m	Anti-rodent grid made of perforated galvanized steel 'L' shaped profile, 30x20 mm, for the protection of ventilated chambers in walls with wooden structures.	0,2	3,20	0,64
	m ²	Sikkens Cetol WF 771 surface treatment system for vertical wood profiles, in three layers. 60 ml/m ² /layer.	1	4,12	4,12
					Subtotal materials 70,82
2		Labour			
	h	Senior installer	0,906	19,42	17,59
	h	Assistant installer	0,906	17,90	16,22
	h	Senior painter	0,138	18,89	2,61
	h	Assistant painter	0,069	17,90	1,24
					Subtotal of labour 37,65
3		Additional direct costs			
	%	Additional direct costs	2	108,47	2,17
					Direct costs (1+2+3) 110,64

Carballeda de Saa House

Carballeda de Saa (Ourense)
Mol Arquitectura

**Heat-treated pine
SuperPan Tech P5
Spruce laminate
Bleached pine with
varnish.**

Structural, furnishings
and panelling.

Photographs by
Héctor Santos-Díez

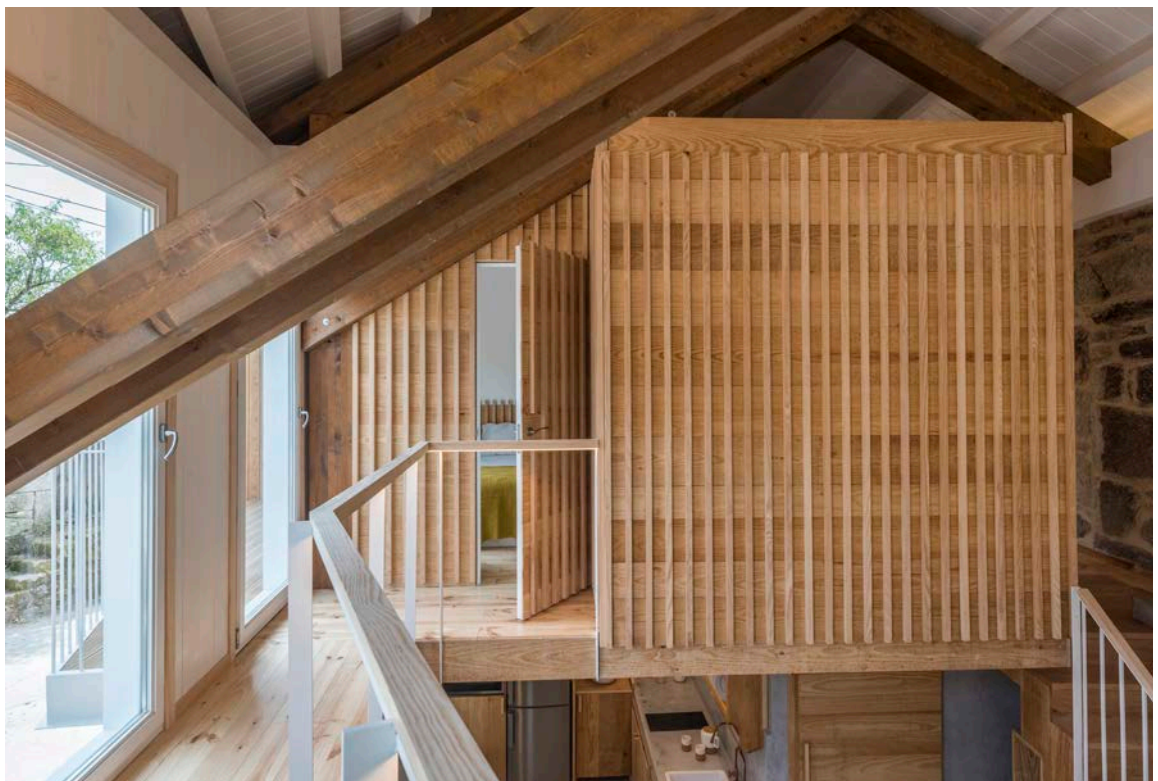
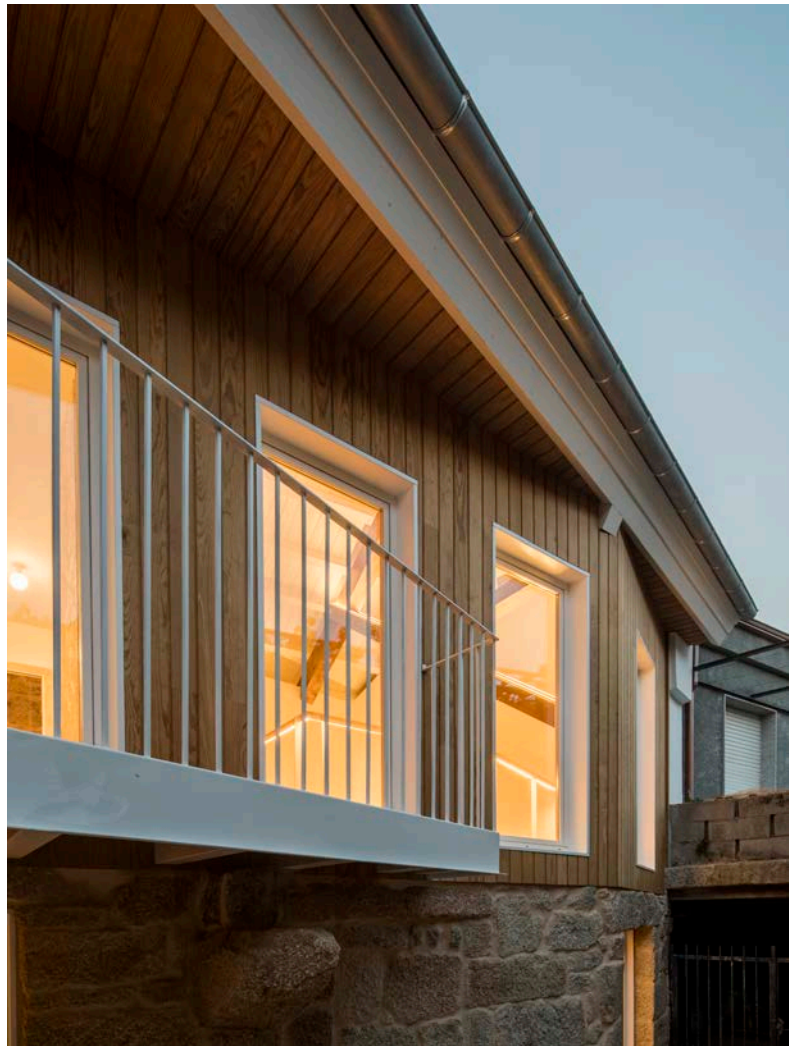

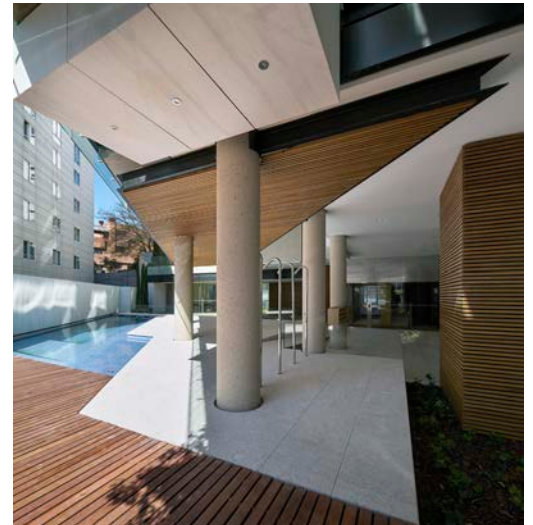
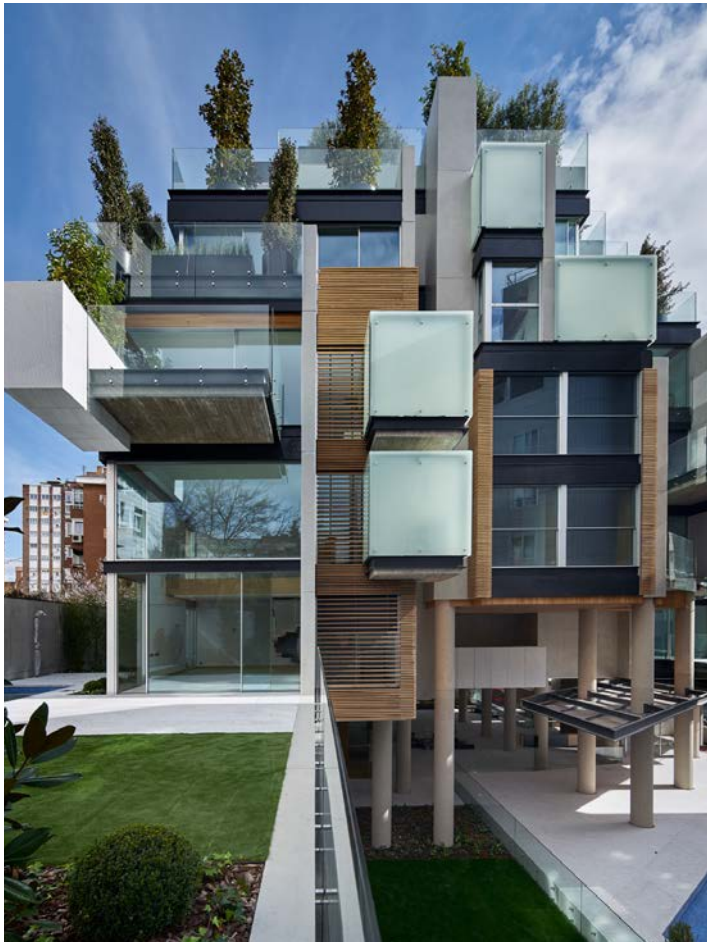

Paseo de la Habana 75

Madrid
Bueso-Inchausti &
Rein Arquitectos

Thermopine Savia

Thermopine Façade
lattices and roofs for
outdoor common areas.

Photographs by
Alfonso Quiroga

3

Gradpanel System

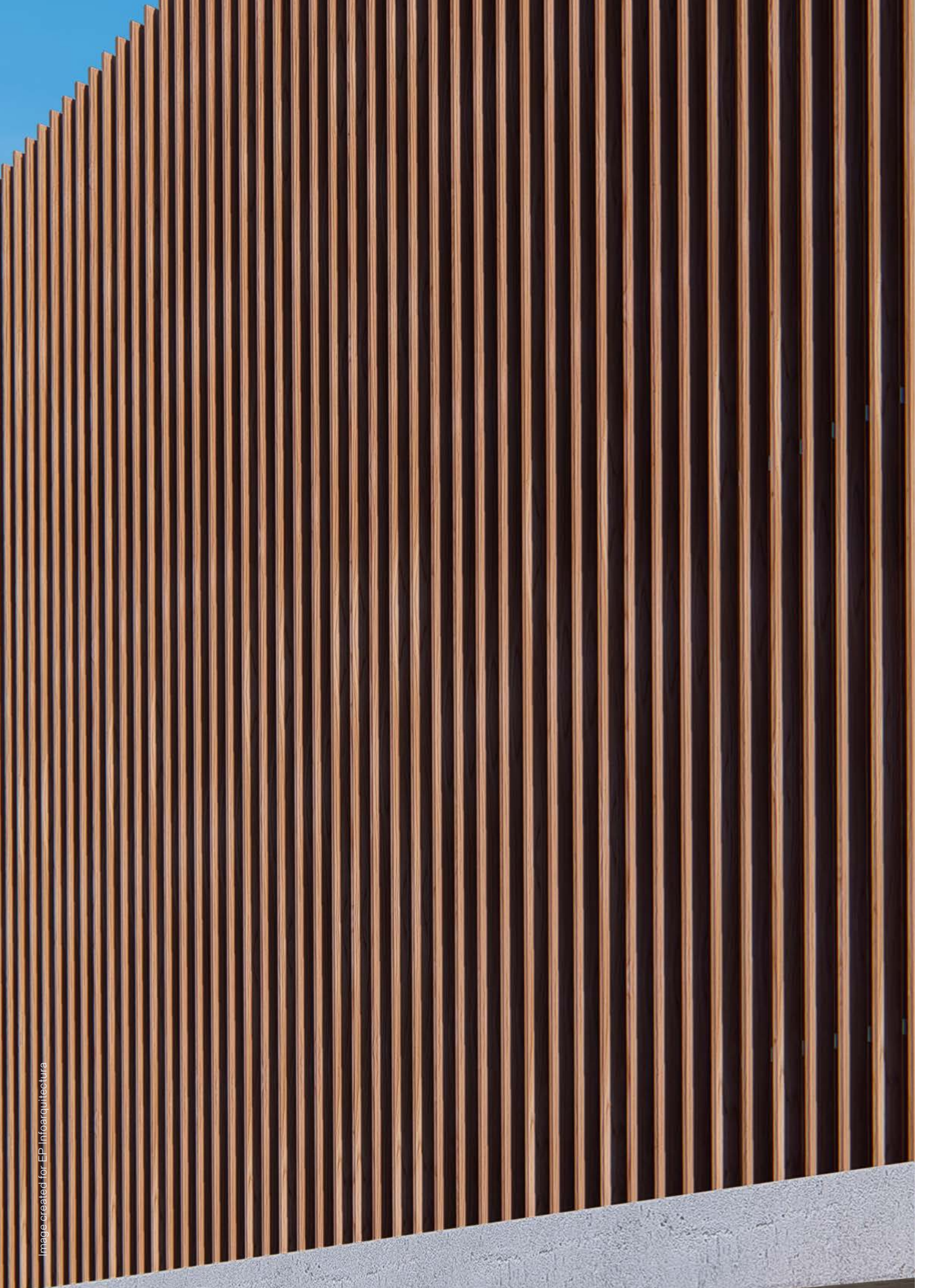

Gradpanel Savia Thermopine

Using the Gradpanel system with ThermoPine, Gradhermetic and Finsa are bringing a technical solution to architectural coverings that provides the beauty, serenity, warmth and well-being offered by wood.



















This collaborative symbiosis between the two companies allows them to offer the designer a sustainable technological solution such as heat-treated pine within the Gradpanel system, which is a benchmark in terms of solar control and decorative cladding for all types of
of façades.

At Finsa, for this application, thanks to our R+D+i department, we have developed the specific quality of heat-treated pine that guarantees dimensional stability, durability and beauty for reference applications at an architectural level, such as the façade of a building.

Gradpanel Thermopine Savia was awarded the Advanced Architecture Awards 2020 at the Arquitectura Avanzada 4.0 de Rebuild congress, in the category "Innovation of product, material or system".

Pictograms guide

General characteristics

	LATTICES	Lattices with a high aesthetic value, warmth, and elegance that bring comfort to the inside of the building.		FIXED SLATS	Lattices with fixed slats.
	BUTT JOINT LAYOUT	Its application on faces allows the slats to have a layout with a continuous solution with butt joints.		FINGERJOINT	Heat-treated pine composition. Finger joint only.
	WEIGHT OF LATTICES	Approximate weight of lattices: In CL W 35, 14,80kg/m ² In CL W 50, 13,30kg/m ² In CL W 80, 18,50kg/m ² In PW 140, 10,80 kg/m ²		SLIDING AND LIFTING MOTOR	Motor-driven applications: sliding and lifting.
	MAXIMUM LENGTH OF SLAT	Maximum length between slat supports. Variable according to application. In CL W 35, 1500mm. In CL W 50/80, 1350mm. In P W 140, 1200mm.		ADJUSTABLE SLATS	Adjustable slats connected to an aluminium plate drive rail with self-locking stainless steel screws.
	MANUAL ACTION	Adjustment of the slats by manual action. Linear cylinder.		LINEAR AND TUBULAR MOTOR	Adjustment of the slats using a linear electric motor (visible) and a tubular motor (hidden). Only with 50x50mm profile frames.
	CONFIGURABLE SOLUTIONS	Option for configurable solutions alternating slats from the same CL W series.		SQUARE SECTION	Square section slats.
	EQUIVALENT IMAGE	Equivalent image from inside and outside the building.		STEEL CLAMPS	Attachment of fixed slats with stainless steel clamps.
	ON UPRIGHTS	Installation on uprights for face application and on frames for all other applications.		ALUMINIUM END CAPS	Set of laser-cut aluminium end pieces, powder-coated.
	FIXED AND RETRACTABLE AXLES	Fixed and retractable zinc-plated steel slat adjustment axles 07mm.		WIREFREE RTS	Wirefree RTS (Hidden) solar tubular motor drive. 50x50mm smooth frames. (Only fixed and sliding frame applications).
	PEFC WOODS	Wood from protected and sustainably-managed forests that have the PEFC seal.			

Frames



EXTRUDED
ALUMINIUM



QUALICOAT
POWDER
FINISH



QUALANOD
ANODIZED
FINISH



GRADCOLORS
FINISH



LAYERED WOODEN
FINISH

Wooden slats



HEAT-TREATED
PINE



VARNISH
TREATED
FINISH

Layout



HORIZONTAL



VERTICAL
(WITH LOWER
ANGLE)

Wind



CLASS 6
RESISTANCE

Home automation



OPTION OF
SMART FAÇADE

Energy efficiency and sustainability

The Gradpanel system with ThermoPine is a sustainable, low environmental impact façade system that is recyclable.

The materials used in the system offer a durable heat-treated pine wood cladding that has a minimal carbon footprint which, together with Gradhermetic's recycled aluminium substructure, allows a skin to be designed for buildings that has a low environmental impact.

The various lattices provide the building with a skin that reduces the solar gains of the building in areas that are excessively exposed to the sun. This increases the energy savings of the building by reducing the energy required for air-conditioning in summer and winter, thanks to the various applications of the system.

Residential project with Gradpanel system.



Image made by EP Infoarquitectura

Qualities and characteristics

Qualities

Standard

Fire performance DS2, d0.

Fireproof

Quality currently under development to achieve BS2, d0. Better performance than required by CTE DB SI (BS3, d0).

Characteristics

Supplied with varnish protection, which gives it colour stability after initial solar degradation and protection against atmospheric agents.

Selected pine wood, without knots or cracks.

Connected with a finger joint that gives it stability and allows for part selection.

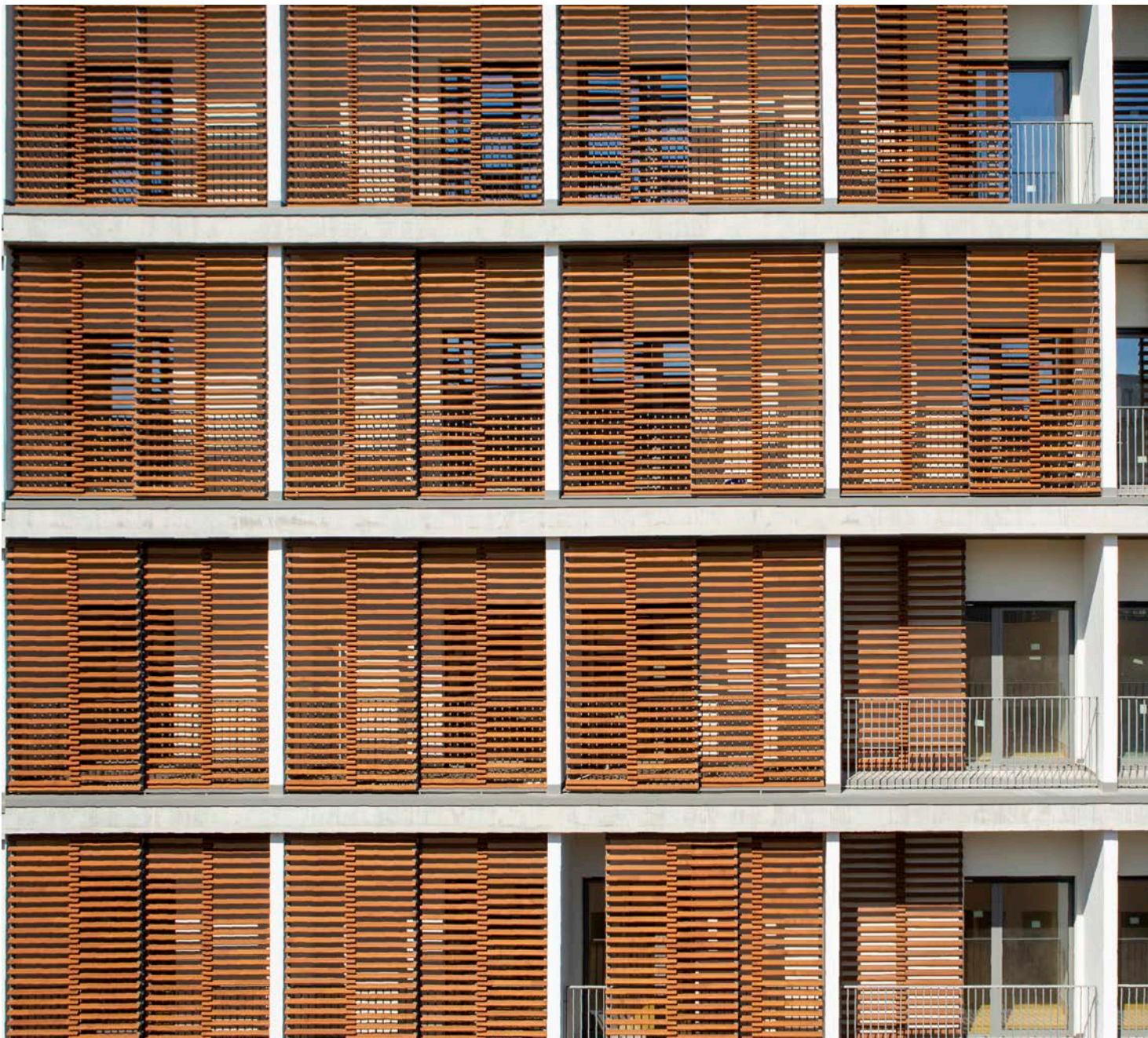

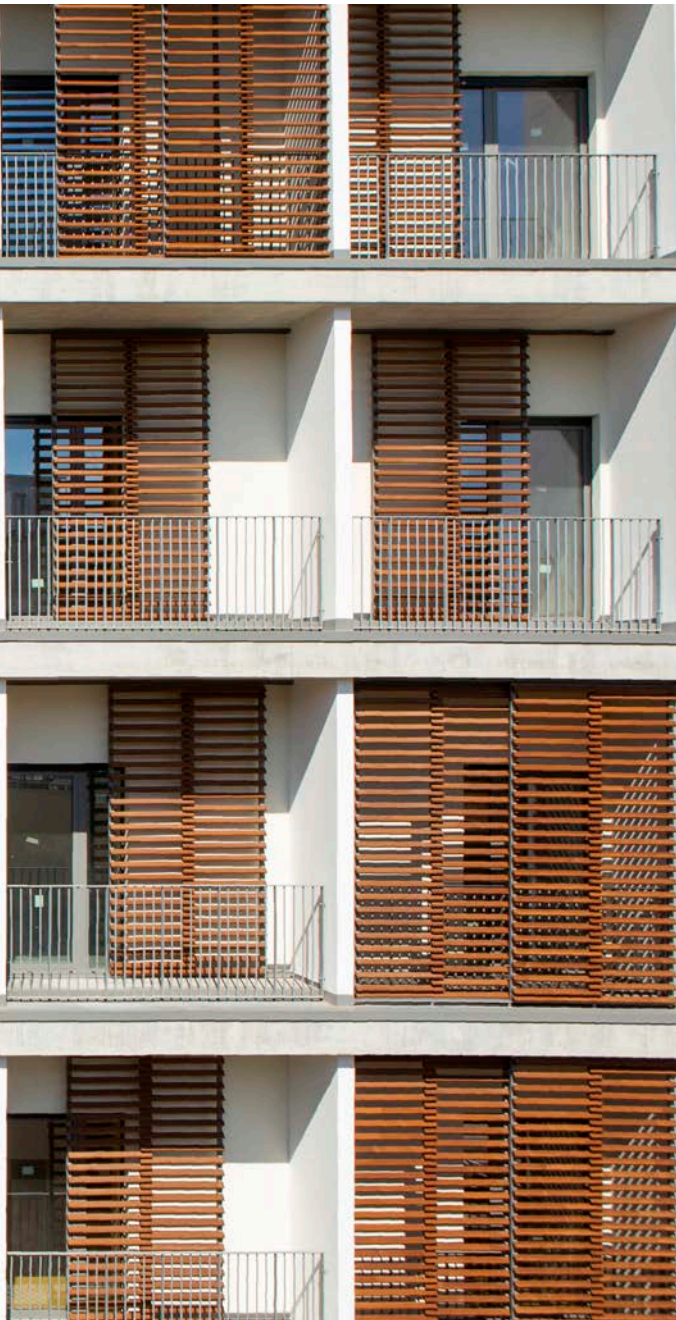

Hospital of Bari
Bari (Italia)
Pinearq Arquitectura

Gradpanel Savia
Thermopine

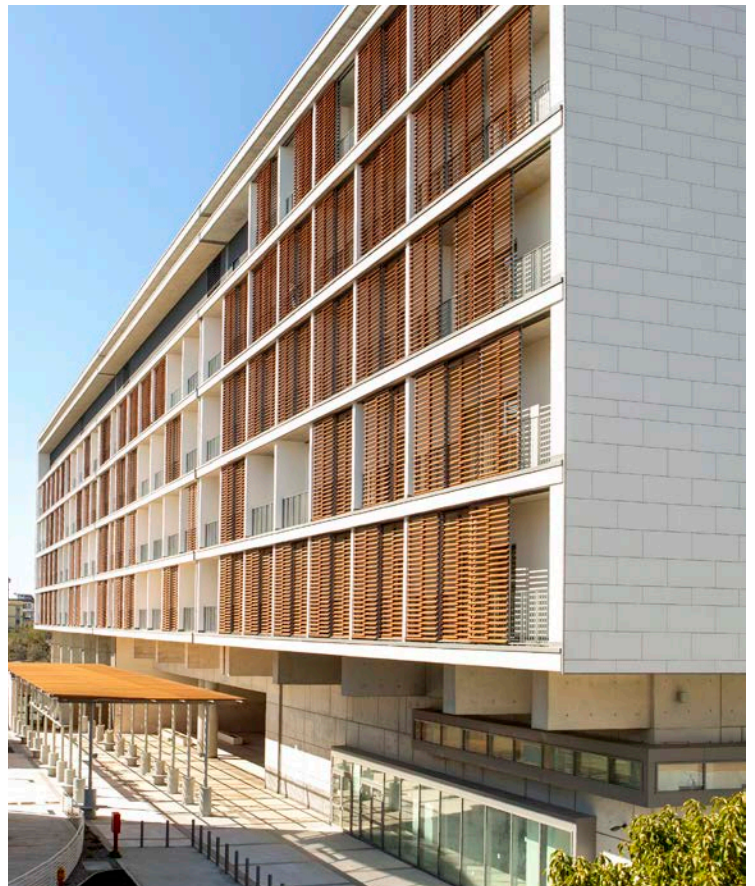



CL W Series

Its great beauty creates an image that combines abstraction and warmth, which is difficult to find in any other material. Furthermore, wood guarantees a durability and indeformability that lasts throughout the life of the building, and it retains its colour, provided it undergoes periodic maintenance.

Models



CL W 35

Fixed slat
Square shape
Savia Thermopine
35x35mm section



CL W 50

Fixed slat
Rectangular shape
Savia Thermopine
50x17 mm section



CL W 80

Fixed slat
Rectangular shape
Savia Thermopine
80x17 mm section

CL W 35

General view

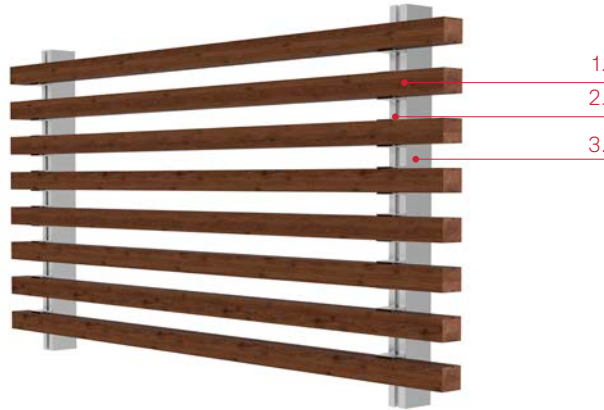

1. Wooden slat in Thermopine.
2. Stainless steel clamp.
3. Extruded aluminium upright.

Wood details



Stainless steel clamp and slat.

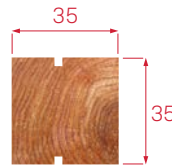

Slat section
(Measurements in mm).

Structure details



over support angle vertical slat (depending on projects).



Stainless steel clamp.

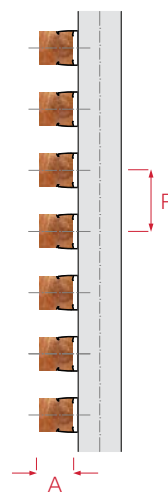

Section view

P= 70mm*.
A= 39-42mm.

(*) Standard gap.
Option for variable gap.

Applications

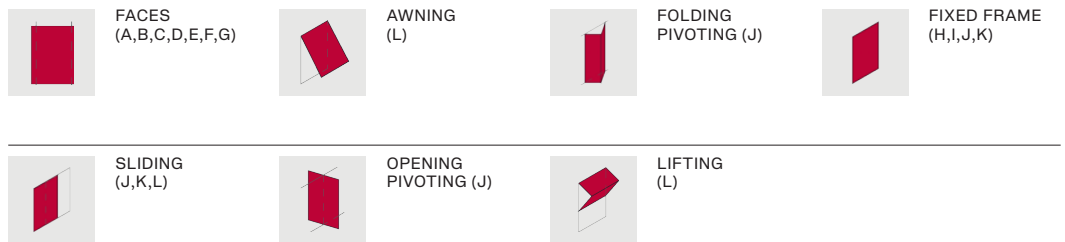

Profiles

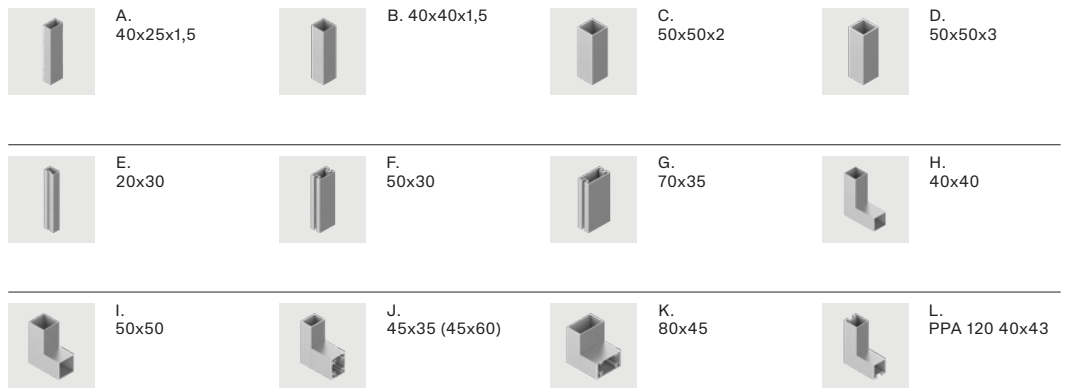

Characteristics

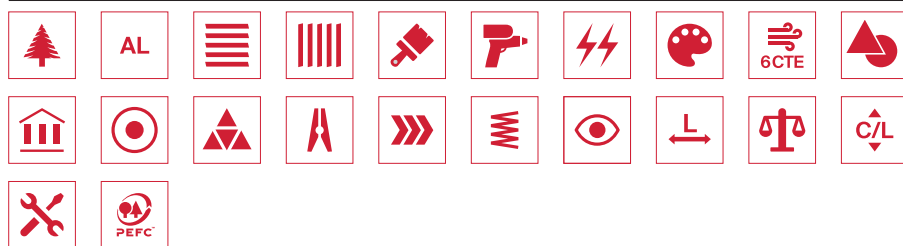

CL W 50 and CL W 80

General view

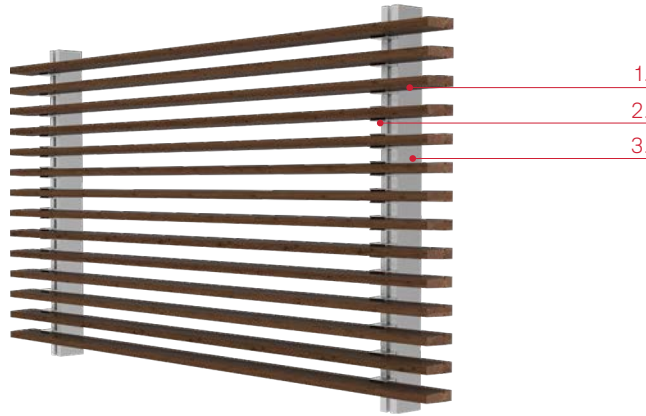

1. Wooden slat in Thermopine.
2. Stainless steel clamp.
3. Extruded aluminium upright.

Wood details



Stainless steel clamp and slat.

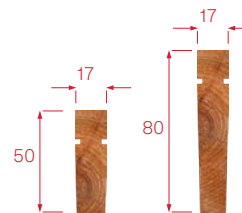

Slat section
(Measurements in mm).

Structure details

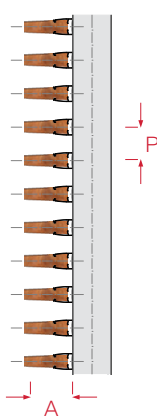

Section view

P= 40mm.*
A= 57mm.
(* Standard gap.
Option for variable gap.

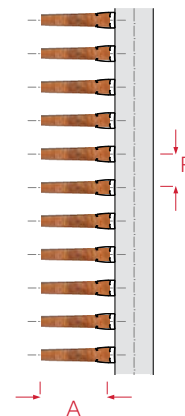

Section view

P= 40mm.*
A= 87mm.
(* Standard gap.
Option for variable gap.

Structure details



Lower support angle vertical slat (depending on projects).



Stainless steel clamp.

Applications



FACES
(A, B, C, D, E, F, G)



AWNING
(L)



FIXED FRAME
(H, I, J, K)



SLIDING
(J, K, L)



LIFTING
(L)

Profiles



A.
40x25x1,5



B. 40x40x1,5



C.
50x50x2



D.
50x50x3



E.
20x30



F.
50x30



G.
70x35



H.
40x40



I.
50x50



J.
45x35 (45x60)



K.
80x45



L.
PPA 120 40x43

Characteristics





Series P W 140

The P W Series consists of fixed or adjustable heat-treated pine slats.

The combination of slats with extruded aluminium frames forms this elegant composition which is also characterised by the fact that it generates changing, warm façades.

This series offers a level of complete solar control, allowing opaque surfaces in the most sun-exposed orientations of the building, with total adjustments of the slats.

Characteristics



P W 140

Fixed and adjustable slat Flat shape with overlap ThermoPine Wood 134.5 x 18.7mm rectangular section.

P W 140

General view

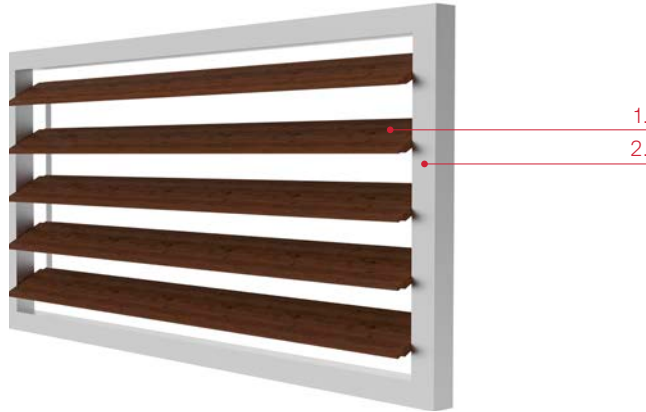

1. Wooden slat in Thermopine.
2. Extruded aluminium frame.

Wood details

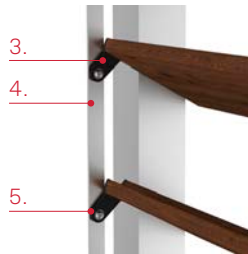

3. Aluminium end piece treated.
4. Drive rail with self-locking screws.
5. Self-locking screws.

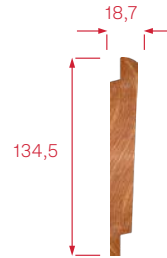

Slat section
(Measurements in mm).

Structure details



Aluminium end piece and pivot embedded in the slat.

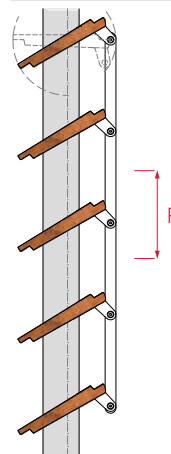

Section view
P= 127mm.*.
(* Standard gap.
Fixed and adjustable.

Applications

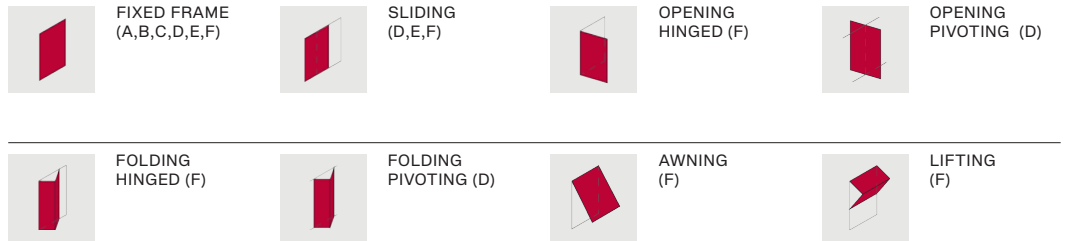

Profiles

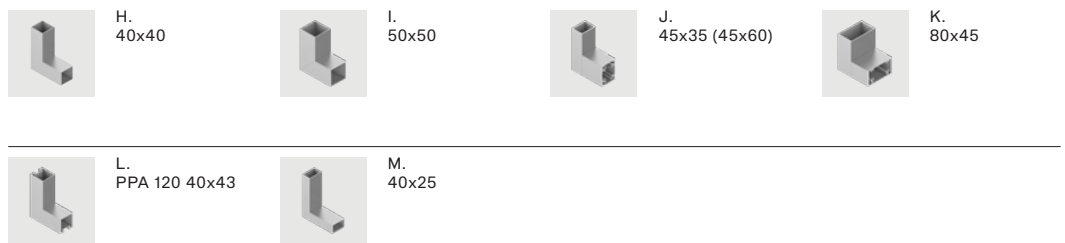

Characteristics





Applications

Gradpanel with Thermopine brings aesthetics and functionality to building façades with different lattice application systems, as well as increasing sustainability and energy efficiency.

The elegance of the application systems allows the architect to make façades multi-purpose with their movements, transmitting different atmospheres depending on the status of the position of each application.

The engineering on which each application is based makes it the perfect solution, providing the people who live in the buildings with a better quality of life.

Summary of applications

Face



Fixed frame

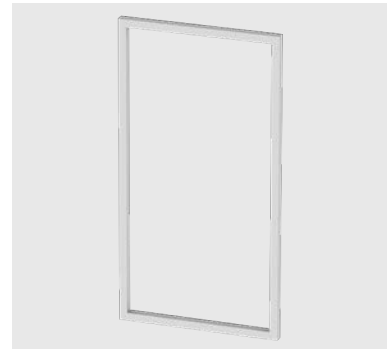

Sliding



Sliding motorized



Opening hinged

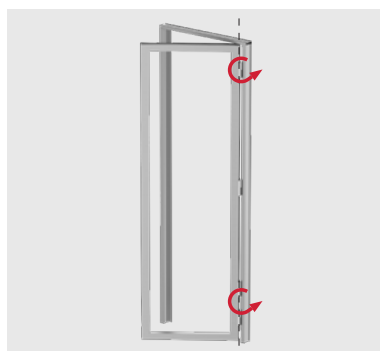

Opening pivoting



Awning

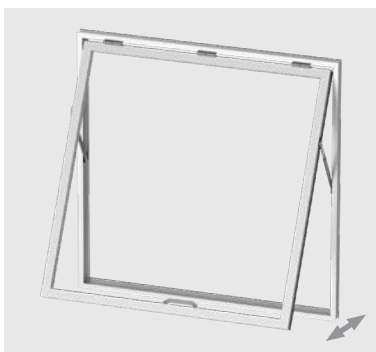

Folding hinged



Folding pivoting



Lifting

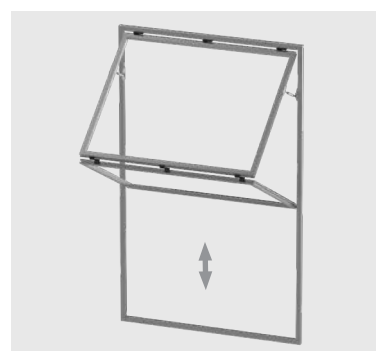

Lifting motorized

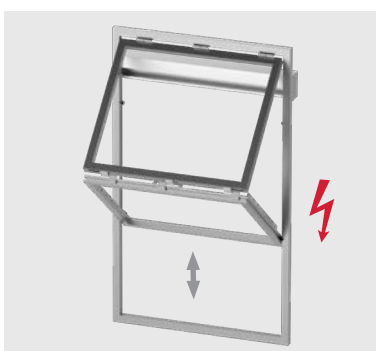

Face

CL W

Lattice systems for application on faces for building cladding as ventilated façades or curtain walls, made with continuous slat solar protection (located in front of the supporting profiles), fixed, fixed to frames, uprights, supports or joists, hidden behind the slats.



Characteristics



Application layout

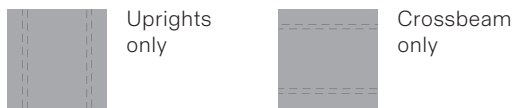

Profiles

Smooth uprights or crossbeams

Slotted uprights or crossbeams

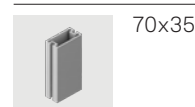
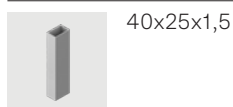

Attachment systems for frames and uprights

Uprights or crossbeams

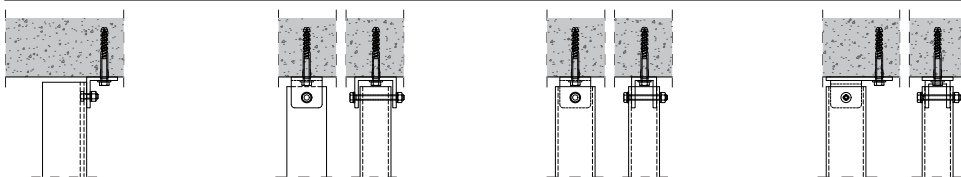

1. Bracket with slotted upright.
2. External anchor for smooth or slotted upright.
3. Internal anchor for smooth or slotted upright.
4. Off-centre internal anchor for smooth or slotted upright.

Montantes ou travessas

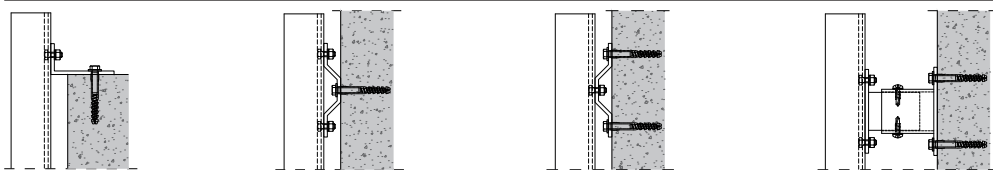

5. Bracket for slotted upright.
6. Double omega fastening for slotted upright.
7. Single omega fastening for slotted uprights.
8. Adjustable steel support for slotted uprights.

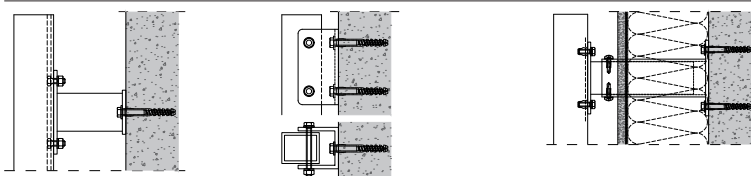

9. Fixed steel bracket for slotted upright.
10. Steel U-bracket for smooth or slotted upright.
11. Solution with SATE or FV (min. 12cm).

Fixed frame

CL W
PW

Lattice systems in fixed frame application for fixed panels in openings or façade cladding formed by visible uprights or frames with Gradhermetic solar protection of slats, located between the profiles, adjustable and fixed. The adjustment of the slats can be manual or motorized.



Characteristics



Application layout

Application layout

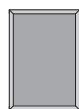

Closed frame



Uprights only



Crossbeams only

Frame models



Simple



Combined dividing crossbeam

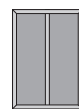

Combined dividing upright



Combined dividing uprights and crossbeams

Profiles

Closed frames (corners)



De topo
45x35
45x60
80x45

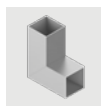

Em esquadria
50x50
40x40

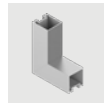

Em esquadria base traseira
(opcional)
PPA 120

Uprights or crossbeams (open frames)

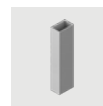

Lisos

25x40x1,5; 40x40x1,5
50x50x2; 50x50x3



Ranhurados

20x30; 50x30; 70x35

Fastening system for frames and uprights

Intramural - frames

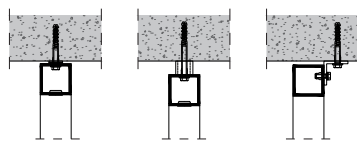

1. Direct
2. Direct with levelling bushing
3. Bracket

Intramural - uprights

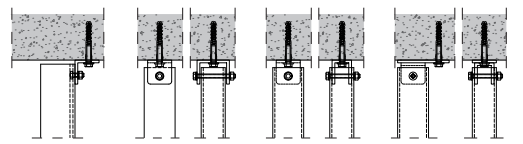

4. Bracket with slotted upright
5. External anchor for smooth or slotted upright
6. Internal anchor for smooth or slotted upright
7. Off-centre internal anchor for smooth or slotted upright

Extramural - frames

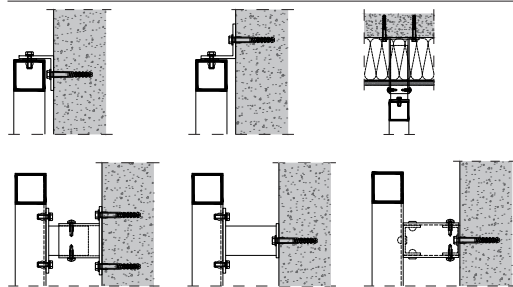

8. Internal bracket
9. External bracket
10. Spacer tube with internal pins
11. Adjustable steel bracket
12. Fixed steel bracket
13. Solution with SATE or FV 12 cm

Extramural - uprights

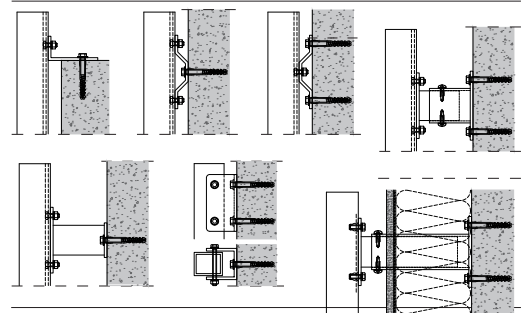

14. Bracket for slotted upright
15. Double omega fastening for slotted upright
16. Single omega fastening for slotted uprights
17. Adjustable steel support for slotted uprights
18. Fixed steel bracket for slotted upright
19. Steel U-bracket for smooth or slotted upright
20. Solution with SATE or FV 12 cm

Sliding

CL W
PW

Lattice systems in sliding application of mobile panels, which can be moved horizontally with upper and lower guides located on the inside or outside of the façades, consisting of panels with visible frames and the fittings and bearings for movement with Gradhermetic solar protection for adjustable and fixed slats. The panels can be moved manually or with a motor.

Closures:

System A: Embedded, passive locking, cremone, cremone with key and key.

System B: Medal, medal with key, lock with key, multipoint, retainer stop.



Characteris-
tics



Application
layout

1 panel/1 guide



2 panels/1 guide



2 panels/2 guides

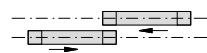

3 panels/3 guides

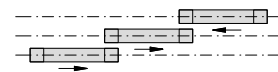

4 panels/2 guides



6 panels/3 guides

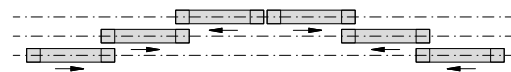

Profiles

System A

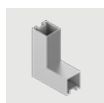

PPA 120

System B



45x35
(45x60)

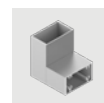

80x45
(80x45)

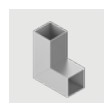

50x50
(solo solar)

System A

Upper guide

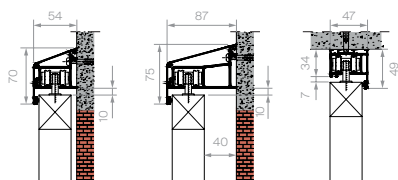

1. Extramural guide 54
2. Extramural guide 87
3. Intramural guide

Lower guide

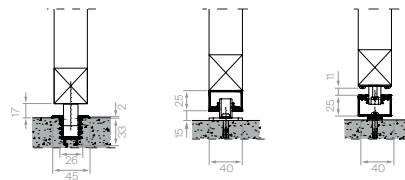

4. Recessed guide
5. Hidden Guide
6. 40x25 visible guide

System B

Upper guide

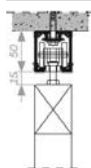

1. 50x45 guide

Lower guide

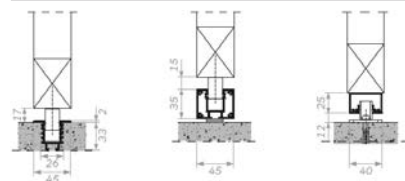

2. Recessed guide
3. Visible guide
4. Hidden Guide

Sliding motorized

CL W
PW

Lattice systems in sliding motorized application of mobile panels, which can be moved horizontally with upper and lower guides located on the inside or outside of the façades, consisting of panels with visible frames and the fittings and bearings for movement with Gradhermetic solar protection for adjustable and fixed slats. The movement of the system is motorized with a motor housed at one end of the guide that transmits the movement to the sliding panel by means of a toothed belt.



Characteristics



Application layout

1 panel / 1 guide / 1 motor



2 panels / 1 guide / 1 motor



2 panel / 2 guides / 2 motors

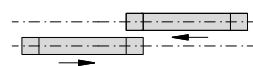

Profiles

System A

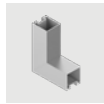

PPA 120
(optional with
rear cover)

System B



45x35
(45x60)



80x45
(80x45)

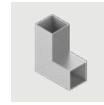

50x50
(solar only)

System A

Upper guide

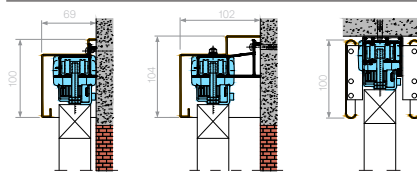

1. Folded AL upper end (extramural guide 54)
2. Folded AL upper end (extramural guide 87)
3. Folded upper edge AL (intramural guide 50x45)

Lower guide

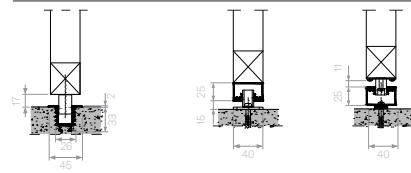

4. Recessed guide
5. Hidden Guide
6. 40x25 visible guide

System B

Upper guide

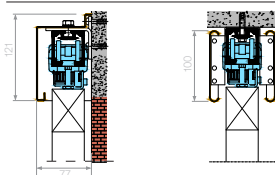

1. Folded AL upper end (extramural guide 50x45)
2. Extruded AL side end (intramural guide 50x45)

Lower guide

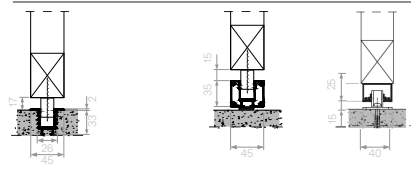

3. Recessed guide
4. Visible guide
5. Hidden Guide

Elevation, dimensional



General view

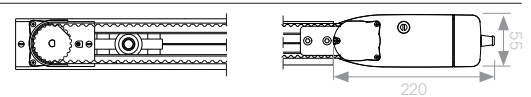

1. Detail A (tension pulley, lower view)
2. Detail B (motor, lower view)

Opening hinged

P W

Lattice systems in opening hinged application, with mobile panels hinged at one end, on one of their vertical axles, onto an outer frame.

The panels consist of panels with visible frames with Gradhermetic solar protection for adjustable and fixed slats.

Closures:

- Embedded.
- Cremone.
- Cremone with key.
- Snap lock and key.
- Lock with key.
- Passive locking (2 panels: only passive panel).



Characteristics



Application layout

1 panel (left opening)

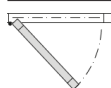
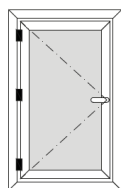

1 panel (right opening)

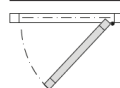
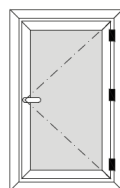

2 panels (left + right opening)

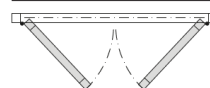
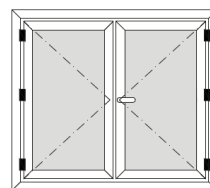

Profiles

Panel profile

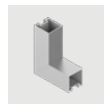

PPA 120



Overlapp
frame



Straight
frame

On-site location

Straight frame profile

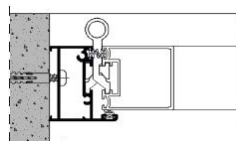

Overlapping frame profile

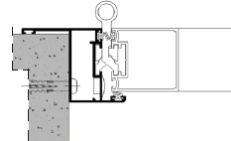

Plan views

Frame profile with overlap 1 panel (ext. opening)

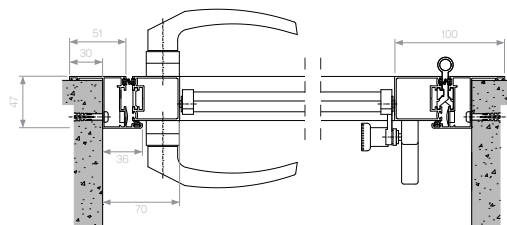

Straight frame profile 1 panel (internal opening)

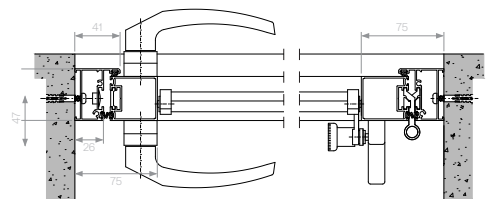

Overlapping frame profile 1 panel (ext. opening)

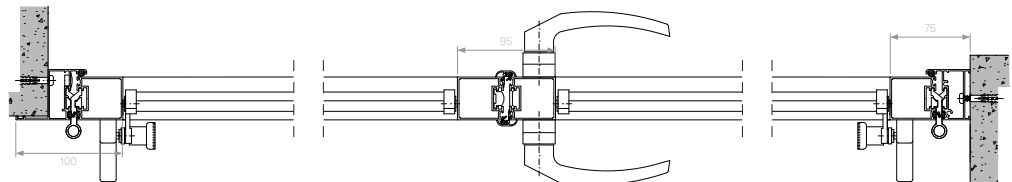

Opening pivoting

CL W
PW

Lattice systems in opening pivoting application of mobile panels, pivoting on a vertical axle near the end of the panel which is fixed to an upper and lower guide or to fixed points. The panels are made up of a panel with a visible frame with Gradhermetic solar protection for adjustable and fixed slats.

Closures:

- Medal.
- Medal with key.
- Lock with key (2 sides).



Characteristics



Application layout

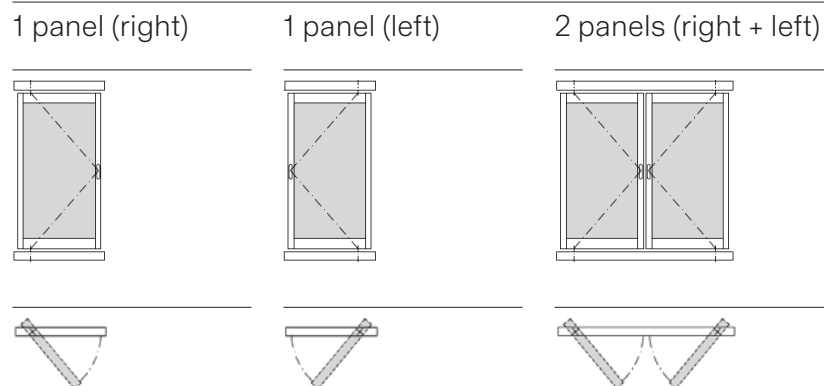

Profiles



45x35
(45x60)

Carpentry distances

Details A and B

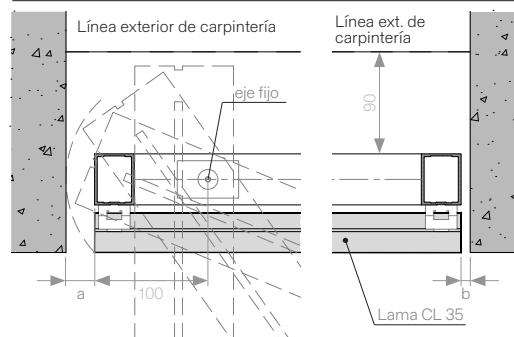

Plan view

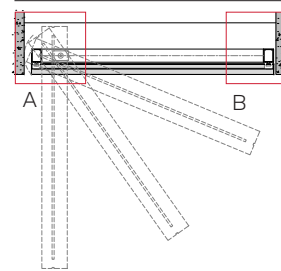

CL W 35 Series

a = 25mm b = 6mm

P W Series

a = 8mm b = 6mm

Guide system

Upper guide

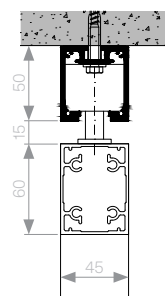

Lower guide (recessed guide and view)

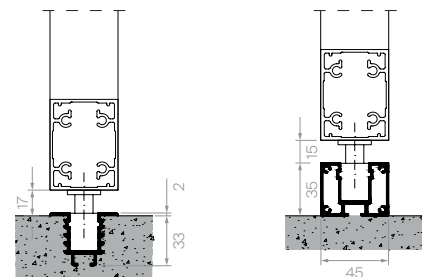

Awning

CL W
P W

Lattice systems in awning application of mobile panels, hinged at the upper end of the frame and projecting outwards in a manner that is limited by the projection compass. The panels consist of panels with visible frames with awning fittings for movement with Gradhermetic solar protection for adjustable and fixed slats.

Closures:

Embedded (optional), pull handle recommended for moving the frame.



Characteristics



Application layout

1 panel (right) upright

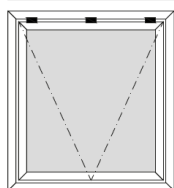

1 panel with central upright

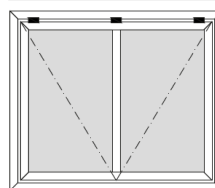

Profiles

Panel profile

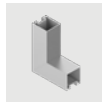

PPA 120



Straight frame

Elevation, plans and sections

Views, sections and positions

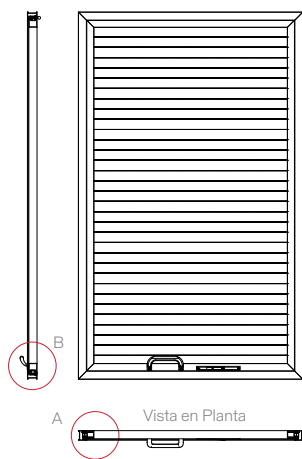

Vista en Planta

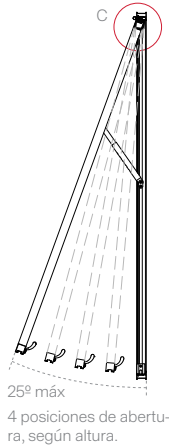

25° máx
4 posiciones de abertura, según altura.

Detail C.1

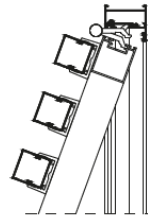

Detail C.2



Detail A

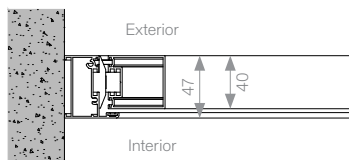

Detail B

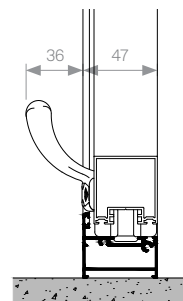

Folding hinged

P W

Lattice systems in folding hinged application, with various mobile panels that are connected together vertically, opening, fixed at one end to the external frame and which can be moved horizontally with upper and lower guide rails. The panels consist of panels with visible frames hinged together in an accordion shape with opening fittings and bearings for horizontal movement and Gradhermetic solar protection for adjustable and fixed slats.



Closures:

Even set of panels: 1 embedded lock.

Odd set of panels: Cremone, cremone with key, snap and key and passive locking.

Characteristics



Application layout

Even

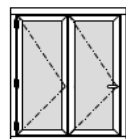

Odd/Even

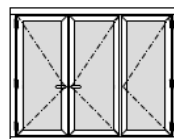

Even/Even

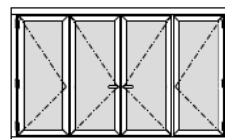

Odd/Odd

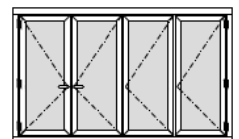

Profiles

Panel profile

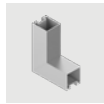

PPA 120

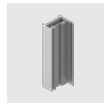

Straight frame
(upright only)

Guide system

Upper guide

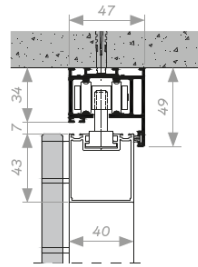

Lower guide (47x35 recessed view)

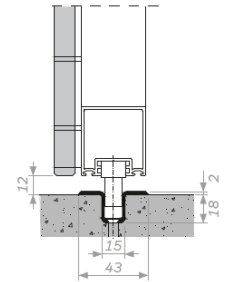
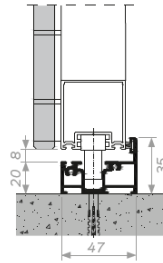

Elevations and section details

Plan view - odd-even solution (2+3)

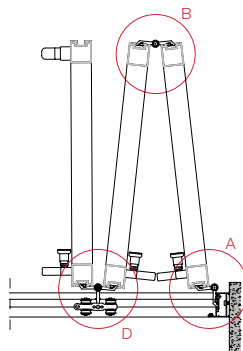
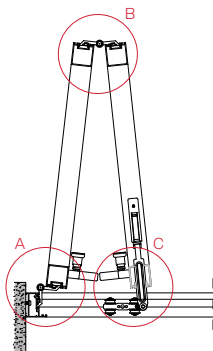

Detail A

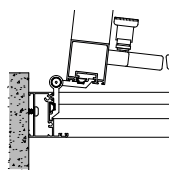

Detail B

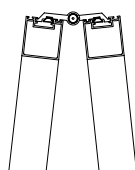

Detail C

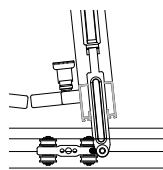

Detail D

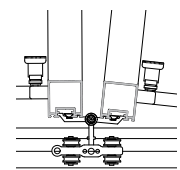

Folding pivoting

CL W
PW

Lattice systems in folding pivoting application with two mobile panels joined together vertically, one panel with a fixed vertical axle and the other panel with a vertical axle that can be moved horizontally with bearings on a set of upper and lower guides. The two panels are made up of panels with visible frames hinged together with Gradhermetic solar protection for adjustable and fixed slats (option of sets of 2 sliding panels).

Closures:

Even set of panels: Medal, medal with key and key lock 2 sides.

Odd set of panels: Medal, medal with key and key lock 2 sides.



Characteristics



Application layout

Even

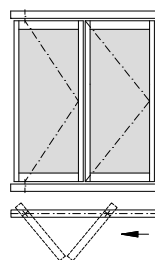

Odd/Even

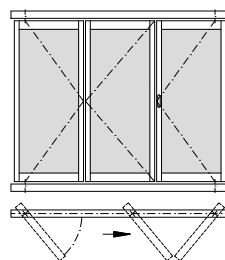

Even/Even

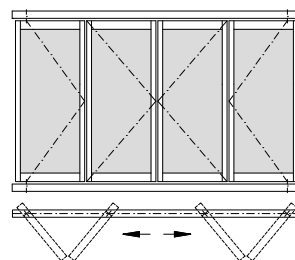

Profiles



45x35
(45x60)

Carpentry distances

Details A y B

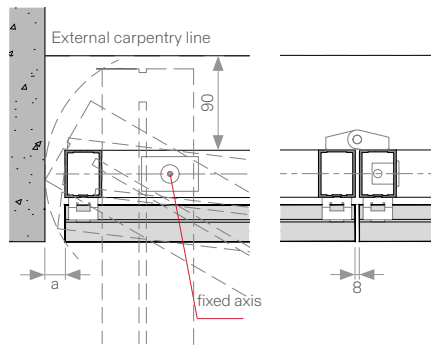

Details C

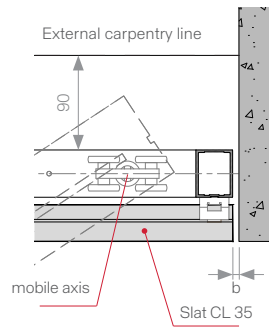

CL W 35 Series
 a = 25mm b=10mm
P W Series
 a = 8mm b =6mm

*** Enclosure (2+0 layout)**

Plan view

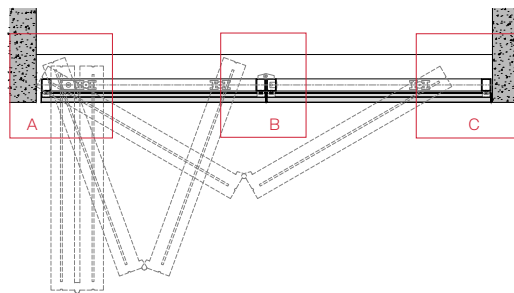

Guide system

Upper guide (50x45 guide)

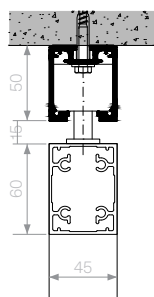

Lower guides (embedded and visible guide)

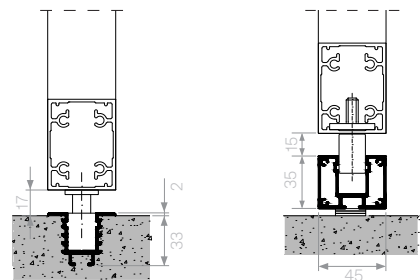

Lifting

CL W
PW

Lattice systems in folding hinged application with several mobile panels joined together vertically, opening, fixed at one end to the external frame and which can be moved horizontally with upper and lower guide rails. The panels consist of panels with visible frames hinged together in an accordion shape with opening fittings and bearings for horizontal movement and Gradhermetic solar protection for adjustable and fixed slats.



Closures:

Even set of panels: 1 embedded lock.

Odd set of panels: Cremone, cremone with key, snap and key and passive locking.

Characteristics



Application layout

Lifting

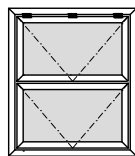

Liftable with central upright

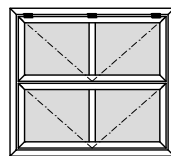

Liftable with lower fixed

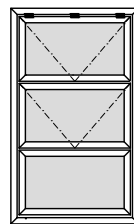

Liftable with central upright and lower fixed

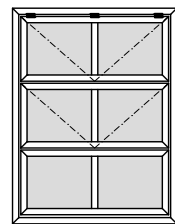

Profiles

Panel profile



PPA 120



PPA 120
External
frame

Elevations, plans and sections

Elevation (external view)

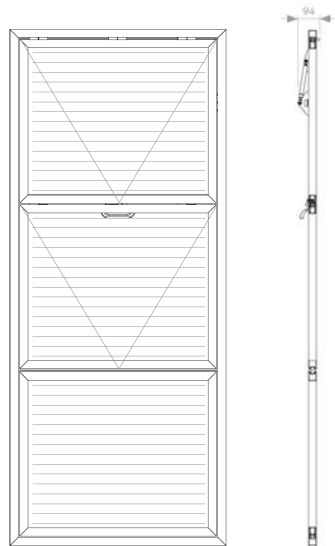

Elevation (internal view)

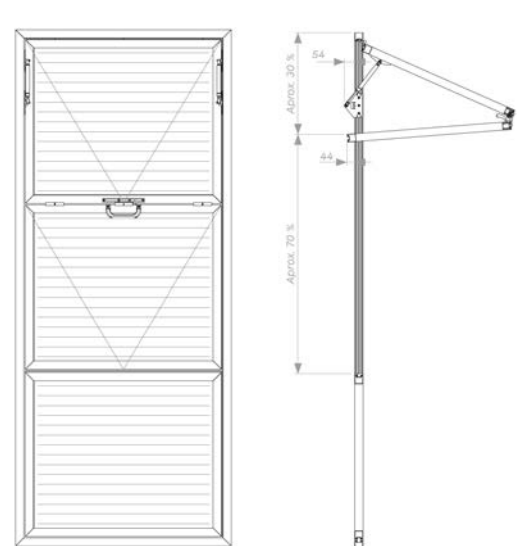

Details A

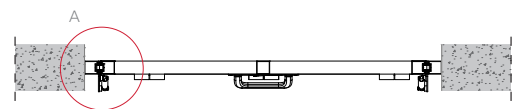
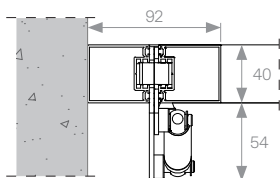

Lifting motorized

CL W
P W

Lattice systems in lifting application with two horizontally connected mobile panels, which can be opened outwards vertically and can be moved upwards on guide rails. The panels are made up of two panels with visible frames hinged together with compensating pistons and guide bearings for vertical movement, with Gradhermetic solar protection for adjustable and fixed slats or perforated sheet panels. The opening of the system is motorized with a tubular motor which is housed in the upper box of the external frame.



Characteristics



Application layout

Lifting

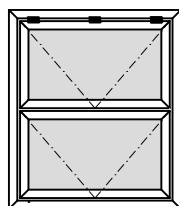

Lifting with central upright

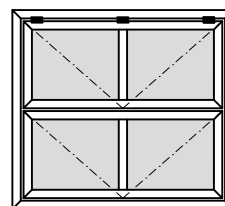

Profiles

Panel

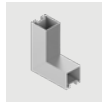

PPA 120



PPA 120
External
frame

Elevation, plans and sections

Elevation (Internal view)

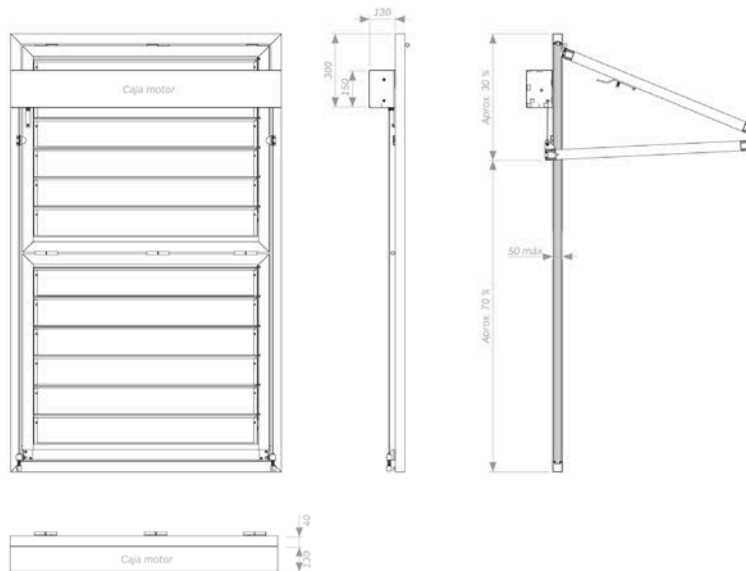

Summary of profiles

Gradpanel CL W
Series ThermoPine

- Possible
- Not possible

Application	Profiles	Slat position	CL W 35	CL W 50	CL W 80	
Face	Upright 40x25x1,5	Horizontal	•	•	•	
		Vertical	•	•	•	
	Upright 40x40x1,5	Horizontal	•	•	•	
		Vertical	•	•	•	
	Upright 50x50x2	Horizontal	•	•	•	
		Vertical	•	•	•	
	Upright 50x50x3	Horizontal	•	•	•	
		Vertical	•	•	•	
	Upright 20x30	Horizontal	•	•	•	
		Vertical	•	•	•	
	Upright 50x30	Horizontal	•	•	•	
		Vertical	•	•	•	
	Upright 70x35	Horizontal	•	•	•	
		Vertical	•	•	•	
Fixed frame	Frame 40x40, 50x50 45x35 (45x60), 80x45	Horizontal	•	•	•	
		Vertical	•	•	•	
Sliding and Sliding motorized	Panel PPA 120 + Guides	Horizontal	•	•	•	
		Vertical	•	•	•	
	Panel 45x35 + Guides	Horizontal	•	•	•	
		Vertical	•	•	•	
	Panel 80x45 + Guides	Horizontal	•	•	•	
		Vertical	•	•	•	
	Panel 50x50 + Guides	Horizontal	•	•	•	
		Vertical	•	•	•	
	Hinged	-	Horizontal	-	-	-
			Vertical	-	-	-
Pivoting	Panel 45x35 + Guides	Horizontal	•	-	-	
		Vertical	•	-	-	
Awning	Panel PPA 120 + Straight Ext. Frame	Horizontal	•	•	•	
		Vertical	•	•	•	
Folding hinged	-	Horizontal	-	-	-	
		Vertical	-	-	-	
Folding pivoting	Panel 45x35 + Guides	Horizontal	•	-	-	
		Vertical	•	-	-	
Lifting	PPA 120 Panel + Ext. Frame PPA 120	Horizontal	•	•	•	
		Vertical	•	•	•	

Gradpanel P W
Series ThermoPine

- Possible
- Not possible

Application	Profiles	Slat position	P W 140
Face	-	Horizontal	-
		Vertical	-
Fixed frame	Frames 40x25, 40x40 50x50, 45x35, 80x45	Horizontal	•
		Vertical	•
Sliding and Sliding motorized	Panel PPA 120 + Guides	Horizontal	•
	Panel 45x35 + Guides	Horizontal	•
	Panel 80x45 + Guides	Horizontal	•
	Panel 50x50 + Guides	Horizontal	•
Hinged	PPA120 Panel + Straight/overlapping Ext. Frame	Horizontal	•
Pivoting	Panels 45x35 + Guides	Horizontal	•
Awning	PPA120 Panel + Straight Ext. Frame	Horizontal	•
Folding hinged	PPA120 panel + Straight/overlapping Ext. Frame	Horizontal	•
Folding pivoting	Panel 45x35 + Guides	Horizontal	•
Folding sliding	Panel 45x35 + Guides	Horizontal	•
Lifting	Panel PPA 120 Ext. Frame PPA120	Horizontal	•



Tiana

res en
WW

BAUER

Local branches

Spain

Northwest

Santiago de
Compostela
T. +34 981 99 31 01
noroeste@finsa.es

North

Logroño
T. +34 941 20 35 00
norte@finsa.es

Levante

Alicante
T. +34 965 12 44 99
sureste@finsa.es

Levante

Valencia
T. +34 96 120 20 13
levante@finsa.es

Catalonia

Barcelona
T. +34 93 703 81 00
catalunya@finsa.es

Centre

Madrid
T. +34 91 212 61 00
centro@finsa.es

South

Seville
T. +34 95 502 31 00
sur@finsa.es

South

Jaen
T. +34 95 322 44 50
sur@finsa.es

International

France — Morcenx

T. +33 558 82 59 00
finsafrance@finsa.com

France — Saint Avertin

T. +33 247 28 06 07
france@finsa.es

Ireland — Drogheda

T. +353 619 210 38
commercial-ffp@
finsa.com

Ireland — Scariff

T. +353 619 210 38
commercial-ffp@
finsa.com

Italy

T. +39 0173 64 607
italia@finsa.es

The Netherlands

T. +31 118 47 12 22
holland@finsa.es

Poland

T. +48 58 627 32 00
polska@finsa.es

Portugal

T. +351 22 55 74 08 /1 /2
luso@finsa.es

United Kingdom

T. +44 (0) 151 651 24 00
uk@finsa.com

Latin America

T. +507 398 2155
latinoamerica@
finsa.com

Morocco

T. +212 (0) 614 56 25 79
finsamaroc@finsa.com

U.A.E.

T. +971 4 880 95 11
finsame@finsa.es

Export

Export

Santiago de
Compostela
T. +34 981 99 31 24
export@finsa.es

Finsa